

ELECTRIC COOLING /  
ELECTRIC HEATING  
PACKAGED UNIT



FORM NO. MCE-100 (06/2025)



### MODEL NUMBER GUIDE

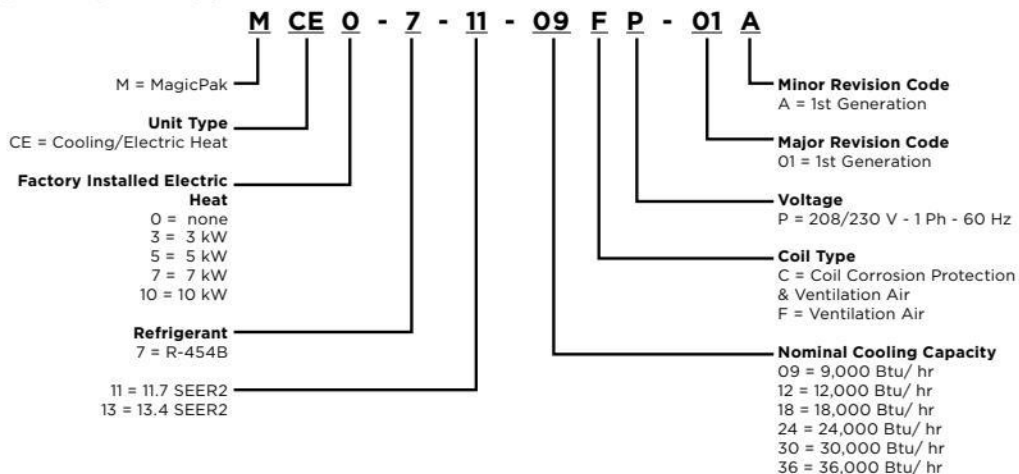

\* Check that equipment complies with all applicable building codes, laws, and regulations for its intended use prior to installation.

**CONTENTS**

<b>APPLICATIONS .....</b>	<b>3</b>
<b>UNIT APPROVALS .....</b>	<b>3</b>
<b>WARRANTY .....</b>	<b>3</b>
<b>STANDARD FEATURES .....</b>	<b>3</b>
<b>OPTIONS &amp; ACCESSORIES .....</b>	<b>4</b>
FACTORY-INSTALLED OPTIONS.....	4
FIELD-INSTALLED ACCESSORIES.....	4
<b>UNIT ELECTRICAL AND PHYSICAL DATA .....</b>	<b>6</b>
<b>UNIT DIMENSIONS (IN.) .....</b>	<b>7</b>
<b>MINIMUM CLEARANCES.....</b>	<b>8</b>
<b>OUTDOOR SOUND RATING &amp; CABINET AIR LEAKAGE .....</b>	<b>9</b>
<b>FACTORY FILTER SIZE (IN.) AND PRESSURE DROP (IN. W.C.).....</b>	<b>9</b>
<b>VENTILATION AIR CAPABILITY .....</b>	<b>10</b>
<b>WALL SLEEVES &amp; LOUVERS .....</b>	<b>11</b>
<b>SCCR ACCESSORY .....</b>	<b>12</b>
<b>CRANKCASE HEATER.....</b>	<b>12</b>
<b>RATED COOLING &amp; HEATING PERFORMANCE.....</b>	<b>13</b>
<b>BLOWER PERFORMANCE .....</b>	<b>15</b>

## APPLICATIONS

- MagicPak units are designed for use in all multifamily applications, such as: apartments, condominiums, student housing and senior living
- Installation in conditioned and non-conditioned mechanical spaces

## UNIT APPROVALS

### ETL (INTERTEK)

- Design certified by Intertek (ETL) to latest edition of UL 60335-2-40
- Certified for the U.S. and Canada
- Certified for less than 1.4% cabinet air leakage using ASHRAE Standard 193
- Factory-installed electric heaters are ETL listed for the U.S. and Canada
- Rated with a 5kA Short Circuit Current Rating (SCCR) in accordance with RMS Symmetrical per UL 508A

### AHRI/DOE

- Certified to AHRI Standard 210/240-2023; refer to the AHRI Directory for AHRI certificates
- Rated and tested in accordance with DOE test procedures (latest edition) and Federal Trade Commission (FTC) labeling regulations

### COIL CORROSION PROTECTION

- Epoxy coating is specifically designed for use on HVAC type coils and demonstrates 6800+ hours of Sea Water Acetic Acid Testing (SWAAT) per ASTM G85:A3

### SOUND RATING

- Outdoor sound level measurements tested per ANSI/AHRI Standard 270
- Refer to Outdoor Sound Rating & Cabinet Air Leakage table for additional details

### ALUMINUM LOUVER - PAINT SPECS

- Standard and impact-resistant louvers meet AAMA 2605 specifications

## WARRANTY

### COMPRESSOR

- Five (5) years limited parts warranty

### ALL OTHER COVERED COMPONENTS

- Refer to Equipment Limited Warranty for additional details

## STANDARD FEATURES

### AIRFLOW CHOICE

- Factory shipped ready for top supply and return duct connections
- Return air may be brought in through the optional front return opening

**NOTE:** If ductwork is attached to the optional front return opening, provisions to service unit filter must be provided

**NOTE:** Filter may need to be relocated to a suitable location outside the cabinet for ease of service

- Front access panel doubles as cover for top return (except 3.0 ton)

**NOTE:** Free Air Return Permitted provided that a refrigerant detection system sensor and control kit are installed.

### ELECTRICAL CONNECTIONS & GAUGE PORTS

- Line voltage knockouts (two concentric) to accommodate field required wire size
- Thermostat connections are located at the top of the cabinet
- Two refrigeration gauge ports are located within the lower compartment of the unit
- Refer to Unit Dimension figure for additional details
- Refer to Unit Electrical and Physical Data table for additional details

### CABINET

- Embossed galvanized steel cabinet
- Indoor section of the cabinet insulated with 0.5 in. dual density fiberglass insulation
- Outdoor section of the cabinet insulated with 0.5 in. weather-resistant polystyrene insulation

### INTERNAL FILTER

- Tool-less filter access
- Factory-installed 1 in. filter rack with washable filter
- Field-supplied filters up to MERV 6 can typically be installed in the filter slot internal to unit in lieu of washable filter, when proper duct design is applied
- If a higher resistance filter is field installed in the unit, the added resistance must be included in the external static pressure and must not exceed 0.5 in. w.c. including ductwork
- Refer to Factory Filter Size and Pressure Drop and Blower Performance tables for additional details

### VENTILATION AIR

- Units are outfitted with ventilation air openings and are shipped with the openings sealed
- Refer to Ventilation Air Capability table and Optional Field-Installed Accessories section for additional details
- Check that equipment complies with all

applicable building codes, laws, and regulations for its intended use prior to installation

#### REFRIGERATION SYSTEM

- Factory charged with R-454B refrigerant
- Factory sealed and tested
- Refrigerant Detection System (RDS) in units charged with refrigerant greater than or equal to 64oz

**NOTE:** RDS kit available for units below 64oz refrigerant charge; see Field-Installed Accessories

#### Indoor and Outdoor Coils

- Copper tube with aluminum fin coils

#### High Pressure Switch

- Shuts off unit if abnormal operating conditions cause the refrigerant liquid pressure to rise above acceptable levels

#### Low Pressure Switch

- Provides loss of charge protection by shutting off unit if refrigerant suction pressure falls below acceptable levels

#### TRANSFORMER

- Rated for 40VA
- Factory wired for 230/240V power supply, and includes field selectable terminal for 208V
- Converts line voltage to 24V for the thermostat and control circuits within the unit

#### SUPPLY AIR BLOWER

##### Constant Torque ECM Blower Motor

- Motor provides specified air volume at 0.1 in. - 0.5 in. w.c. external static pressure
- Blower assembly is easily removed for servicing
- Refer to Blower Performance tables for additional details

##### Electronic Blower Control

- Dedicated blower speed taps for continuous fan, cooling, and heating operation are programmed for optimal airflow and controlled by 24V thermostat signals
- Blower speed adjustment is easily accomplished by speed tap selection
- Fixed blower delays have been selected to enhance comfort
- Refer to Blower Performance tables for additional details

#### OUTDOOR FAN

- Heavy duty, fully enclosed and weatherproof
- Aluminum fan blades

#### CONDENSATE MANAGEMENT

##### Primary Drain Pan

- Antimicrobial protection: drain pan is injected with an antibacterial agent that destabilizes the membrane of microorganism cells, disrupting the cellular function of odor-causing mold and bacteria so that they can no longer grow or reproduce

##### Overflow Protection

- Indoor drain pan overflow protection switch monitors the condensate level in primary drain pan
- Prevents unit from running if water is sensed

##### Secondary Drain Pan

- Polypropylene wall sleeve base is specifically designed to direct rain water out of the building and in the event of any restriction in the primary drain will act as a redundant overflow protection

#### OPTIONS & ACCESSORIES

#### FACTORY-INSTALLED OPTIONS

##### ELECTRIC HEAT

- Mounted internal to unit cabinet
- Multiple kW sizes available; must specify the electric heating element size (0kW to 10kW)
- Optional two stage electric heat wiring on 7 & 10kW. In order to utilize this option, it will require a thermostat with single stage cooling and two stage heating
- Compatible with 208V, 230V and 240V
- Helix wound nichrome heating elements exposed directly into the air stream resulting in instant heat transfer and low element temperatures
- Cutoff limit control provides positive protection in case of excessive temperatures
- Refer to Rated Cooling & Heating Performance table for additional details

##### CORROSION PROTECTION

- Epoxy coated indoor and outdoor coils

#### FIELD-INSTALLED ACCESSORIES

##### REFRIGERANT DETECTION SYSTEM KIT (RDS)

- For units below 64oz refrigerant charge
- Includes control board, board bracket, harness, leakage sensor, and sensor bracket

**WALL SLEEVES & LOUVERS**

- Units must be installed with approved wall sleeve and louver accessories for safe operation and are required for all installations
- Larger height wall sleeves may be used on smaller tonnage equipment to maintain a uniform wall opening on the building façade
- Refer to Wall Sleeves and Louvers table for additional details

**WALL SLEEVES (ASLEEVE)**

- Penetrates the building envelope and creates a path for condenser air intake and exhaust
- Provides a sealed connection to the unit and a secure attachment foundation for the louvers
- Available in 6 in. to 12 in. depths

**WALL SLEEVE EXTENSION (ASLEEVEXT4)**

- Provides an additional 4 in. of depth to the wall sleeve, for a maximum depth of 16 in.

**LOUVERS****Polypropylene Louvers (ALVRP)**

- Constructed from durable, corrosion-resistant plastic
- Available in four standard colors

**Aluminum Louvers (ALVRAL)**

- Constructed with 6063-T6 grade aluminum
- Available in anodized clear coat, primer (to be painted in the field), standard paint colors and custom colors with paint matching\*

**Impact-Resistant Aluminum Louvers (ALVRALC)**

- Impact and wind load certified up to 186 MPH, risk categories III and IV, and wind exposures C and D
  - ALVRALC-1 & ALVRALC-2: FBC Notice of Acceptance (NOA) 20-0909.03
  - ALVRALC-3, -4 & -7: FBC Notice of Acceptance (NOA) 21-1216.11
- Constructed with 6063-T6 grade aluminum
- Available in anodized clear coat, primer (to be painted in the field), standard paint colors and custom colors with paint matching\*

**CRANKCASE HEATER (ACASE841)**

- Warms compressor crankcase to limit migration of liquid refrigerant back to compressor during off cycle
- Available for models with scroll compressors
- Refer to Crankcase Heater table for additional details

**SHORT CIRCUIT CURRENT RATING KIT (ASCCR)**

- Provides 200kA of SCCR protection
- Refer to SCCR Accessory table for additional details

**FILTERS**

- Field-supplied filters up to MERV 6 can typically be installed in the filter slot internal to unit
- NOTE:** Use of paper frame **not** recommended

**VENTILATION DAMPERS**

- Check that the equipment complies with all applicable building codes, laws, and regulations for its intended use prior to installation

**Motorized Damper w/ Controller (AVADAMP1)**

- Utilizes a ventilation air control module that is field programmable to assist with meeting ASHRAE 62.2 requirements
- Once programmed with values for ventilation air amounts, the control module opens the damper in response to thermostat inputs and monitors the run time
- Upon meeting the ventilation air needs, the control module will close the damper until the start of the next cycle
- If, during an observation period it is determined that thermostat operation alone may not provide the desired ventilation air, the control module can independently operate the unit's indoor blower, in continuous fan mode, and open the damper to aid in providing ventilation air needs

**Motorized Damper w/ Field-Supplied Relay (AVADAMP2)**

- Opens ventilation air damper during indoor blower operation and closes during blower off periods
- Requires field-supplied and installed current sensing relay to detect indoor blower operation

**HYDRONIC COIL**

- Unit may be adapted to include a field-supplied hydronic/hot water coil

**THERMOSTAT**

- Required for all installations (field-supplied)
- Units are individually controlled with conventional 24V thermostat
- Thermostat must be capable of:
  - Single stage cooling and single stage heating (3 and 5 kW single stage electric heat)
  - Single stage cooling and two stage heating (7 and 10 kW two stage electric heat)

\* Certain exclusions apply. Refer to louver manufacturer's literature and warranty documentation.

UNIT ELECTRICAL AND PHYSICAL DATA (208/230 Volt - 1 Phase - 60HZ)<sup>1</sup>

Tonnage	Model	MCA <sup>2</sup>		MOCP <sup>3</sup>		Default SCCR (kA) <sup>4</sup>	Compressor		Outdoor Fan			Indoor Blower		Approx		R454B Charge (OZ.)	R454B Charge (LBS.)	R454B Charge (KG.)		
		208V	230V	208V	230V		Rated Load Amps (RLA)	Locked Rotor Amps (LRA)	Dia. (in)	Nominal RPM	Full Load Amps (FLA)	Rated HP	Wheel D x W (in.)	Full Load Amps (FLA)	Rated HP				(LBS)	(KG)
0.75	MCE0-7-11-09FP-01A	6.5	6.5	15	15	5	4.2	21.8	16	1125	0.9	1/8	9 x 6	0.3	1/3	190	186	35.0	2.2	1.0
	MCE3-7-11-09FP-01A	17.0	19.5	20	20									0.6						
	MCE5-7-11-09FP-01A	22.9	26.3	25	30									1.0						
1.0	MCE0-7-11-12FP-01A	9.1	9.1	15	15	5	6.2	26.4	16	1125	0.9	1/8	9 x 6	0.4	1/3	189	86	32.0	2.0	0.9
	MCE3-7-11-12FP-01A	17.0	19.5	20	20									0.6						
	MCE5-7-11-12FP-01A	22.9	26.3	25	30									1.0						
1.5	MCE0-7-11-18FP-01A	10.5	10.5	15	15	5	6.8	32.7	16	1125	0.9	1/8	9 x 6	1.0	1/3	212	96	56.0	3.5	1.6
	MCE3-7-11-18FP-01A	17.0	19.5	20	20									0.6						
	MCE5-7-11-18FP-01A	22.9	26.3	25	30									1.0						
	MCE7-7-11-18FP-01A	34.3	39.3	35	40									1.4						
	MCE10-7-11-18FP-01A	45.5	52.1	50	60									1.7						
2.0	MCE0-7-11-24FP-01A	14.5	14.5	20	20	5	9.9	41.2	18	1050	0.9	1/8	9 x 6	1.3	1/3	237	108	64.0	4.0	1.8
	MCE5-7-11-24FP-01A	22.8	26.1	25	30									0.9						
	MCE7-7-11-24FP-01A	34.8	39.8	35	40									1.8						
	MCE10-7-11-24FP-01A	46.2	52.9	50	60									2.3						
2.5	MCE0-7-11-30FP-01A	21.3	21.3	30	30	5	14.6	75.6	18	1100	1.6	1/4	10 x 8	1.4	1/2	277	126	64.0	4.0	1.8
	MCE5-7-11-30FP-01A	22.9	26.3	30	30									1.0						
	MCE7-7-11-30FP-01A	34.0	39.0	35	40									1.2						
	MCE10-7-11-30FP-01A	45.2	51.9	50	60									1.5						
3.0	MCE0-7-13-36FP-01A	22.7	22.7	35	35	5	14.4	86.0	18	1100	2.8	1/3	10 x 8	1.9	1/2	306	139	82.0	5.1	2.3
	MCE5-7-13-36FP-01A	22.9	26.3	35	35									1.0						
	MCE7-7-13-36FP-01A	34.1	39.1	35	40									1.3						
	MCE10-7-13-36FP-01A	45.6	52.3	50	60									1.8						

<sup>1</sup> Acceptable voltage range: 197 - 253V

<sup>2</sup> MCA = Minimum Circuit Ampacity

<sup>3</sup> MOCP = Maximum Over Current Protection

<sup>4</sup> SCCR = Short Circuit Current Rating; refer to SCCR Accessory table, up to 200kA

NOTE: Units are rated at 208/230V, but MOCP & MCA values are calculated at 240V

NOTE: The 7.2 and 10 kW heat strips offer a W1 and W2 thermostat connection. Taking advantage of the two heat strip circuits requires a 2-stage thermostat (W1 for electric heat stage 1 and W2 for electric heat stage 2). If a single stage thermostat is used, "pigtail" W1 and W2 wires together when connecting the thermostat wires at the unit.

## UNIT DIMENSIONS (IN.)

Model	A	B*	C	D	E	F	G	H	J	K	L	M	N
MCE*-7-11-09*P MCE*-7-11-12*P MCE*-7-11-18*P	43-7/8	16-7/8	25-1/4	21-1/2	18-5/8	19-1/4	6	8	16	17-1/16	3/4	2-1/4	24-5/8
MCE*-7-11-24*P	47-7/8	18-7/8	27-1/4	24-3/8	20-5/8	21-1/4	6	8	16	19-1/16	3/4	2-5/8	26-5/8
MCE*-7-11-30*P	55-7/8	22-7/8	31-1/4	24-3/8	24-5/8	25-1/4	6	11-3/8	10-7/16	22-7/16	3-3/4	1	30-5/8
MCE*-7-13-36*P	67-7/8	26-7/8	35-1/4	24-3/8	28-5/8	29-1/4	10	11-3/8	10-7/16	22-7/16	3-3/4	1	38-5/8

\* Dimension B represents the height of the optional front return air duct opening.

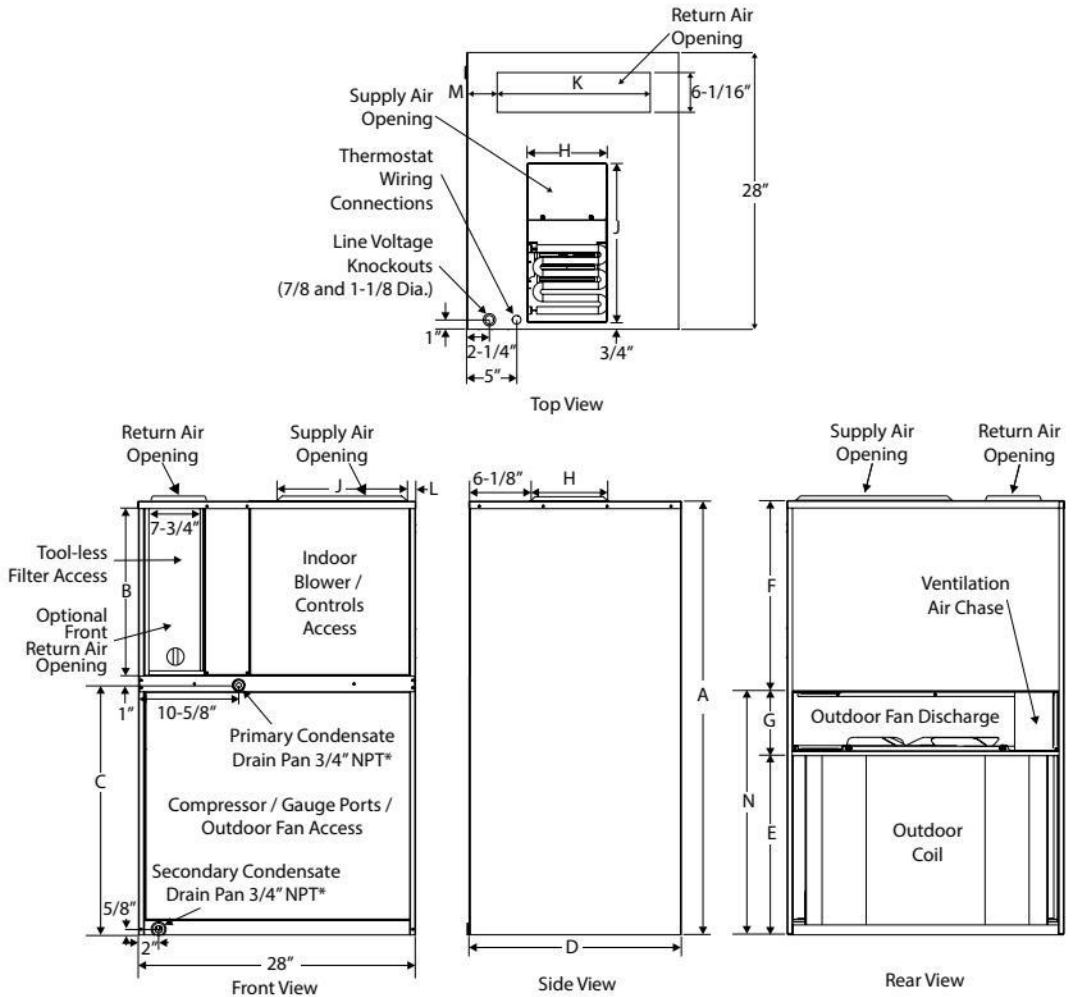

\* Provisions must be made to properly drain condensate from the primary and secondary drain pans.

## MINIMUM CLEARANCES

### Accessibility Clearances

The front of the unit must be accessible for service. A minimum clearance of 30" in front of unit is required for service.

If the unit is enclosed, a door or access panel aligned with the front of the unit is the preferred method of providing access. The door or access panel opening must be a minimum of 30" wide (centered on the unit) and be as tall as the unit.

#### IMPORTANT

The unit must be installed with approved wall sleeve and louver accessories for safe operation. Improper installations could result in property damage, personal injury, or death.

### Supply Duct Clearances

#### Minimum Clearances to Combustible Materials<sup>1</sup>

Front	Sides	Top
0"	0"	0"

<sup>1</sup> Accessibility clearances take precedence

### Unit Clearances

Return Duct Configuration	Unit Height	Minimum Clearances <sup>1</sup>	
		Front	Sides <sup>2</sup>
Ducted Top Opening	All	See Note 2	1"
Ducted Front Opening <sup>5</sup>	All	See Note 2 & 4	1"
Non-Ducted/ Free Return	43"	4"	1"
	48" - 68"	5"	1"

<sup>1</sup> Accessibility clearances take precedence

<sup>2</sup> Clearance must accommodate field-installed condensate drain line / drain trap

<sup>3</sup> Additional clearance required if field-installed condensate drain line/drain trap is routed alongside unit.

<sup>4</sup> Consult local codes for other clearance requirements

<sup>5</sup> If ductwork is attached to the optional front return opening, provisions to service unit filter must be provided

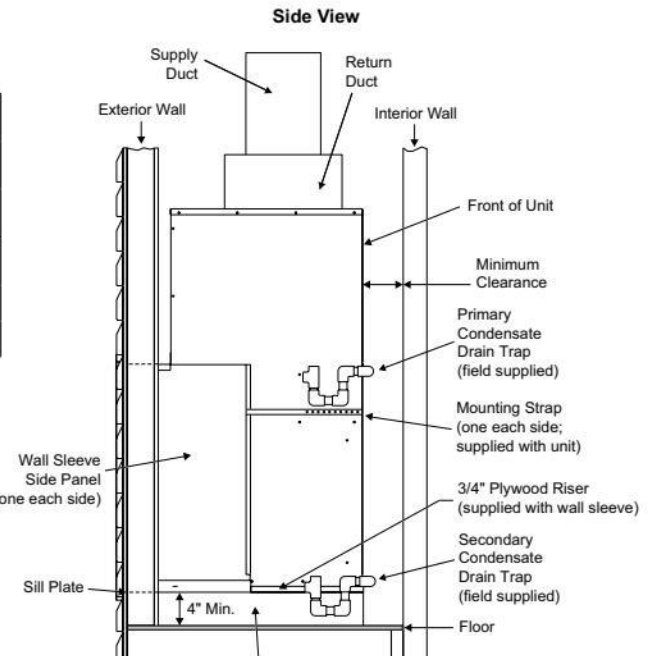
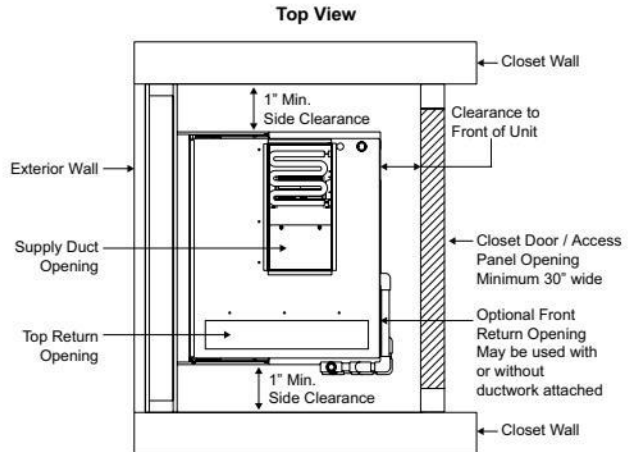

Platform (field supplied) - Unit must be supported by platform, which must be level with sill plate of opening in exterior wall.

**OUTDOOR SOUND RATING & CABINET AIR LEAKAGE**

Model	Outdoor Sound Rating (dBA) <sup>1</sup>	Cabinet Air Leakage (%) <sup>2</sup>
MCE*-7-11-09*P	73	1.4
MCE*-7-11-12*P	73	1.4
MCE*-7-11-18*P	73	1.4
MCE*-7-11-24*P	75	1.4
MCE*-7-11-30*P	79	1.4
MCE*-7-13-36*P	79	1.4

<sup>1</sup> Per ANSI / AHRI Standard 270

<sup>2</sup> Per ASHRAE Standard 193

**FACTORY FILTER SIZE (IN.) AND PRESSURE DROP (IN. W.C.)**

Model	Filter Size	Supply Airflow (CFM)									
		200	300	400	500	600	700	800	900	1000	1100
MCE*-7-11-09*P MCE*-7-11-12*P MCE*-7-11-18*P	18 x 20 x 1	0.01	0.01	0.01	0.02	0.03	0.04	0.05	---	---	---
MCE*-7-11-24*P	20 x 22 x 1	---	0.01	0.01	0.02	0.03	0.03	0.04	---	---	---
MCE*-7-11-30*P	24 x 22 x 1	---	---	---	0.01	0.01	0.02	0.03	0.03	0.04	0.05
MCE*-7-13-36*P	28 x 22 x 1	---	---	---	---	0.01	0.01	0.02	0.02	0.03	0.03

Performance based on factory-provided washable filter installed in the unit. If a higher resistance filter is field installed in the unit, the added resistance must be included in the external static pressure and must not exceed 0.5 in. w.c. including ductwork.

## VENTILATION AIR CAPABILITY

Chart and figure below show the amount of ventilation air as a function of unit tonnage and total External Static Pressure (supply and return).

		Ventilation Air (CFM) *					
		Cumulative Knockouts Removed	Total External Static Pressure (supply + return) **				
			0.1	0.2	0.3	0.4	0.5
0.75, 1.0, 1.5 TON	# 1 Only	7	9	12	15	18	
	#1 thru #2	10	15	20	24	28	
	#1 thru #3	12	18	25	32	38	
	#1 thru #4	18	28	36	45	54	
	#1 thru #5	23	35	46	57	69	
	#1 thru #6	27	41	54	67	80	
	#1 thru #7	32	48	63	78	93	
	#1 thru #8	37	55	73	90	107	
	#1 thru #9	41	61	80	100	118	

2.0, 2.5, 3.0 TON	# 1 Only	21	20	19	17	16
	#1 thru #2	28	27	25	24	22
	#1 thru #3	35	33	32	30	28
	#1 thru #4	45	42	40	38	35
	#1 thru #5	55	52	49	46	43
	#1 thru #6	66	62	59	55	52
	#1 thru #7	79	75	71	66	62
	#1 thru #8	91	86	81	76	71
	#1 thru #9	105	99	94	88	82

\* Assumes proper speed tap adjustments to maintain nominal supply air CFM

\*\* Assumes equal supply and return static pressures

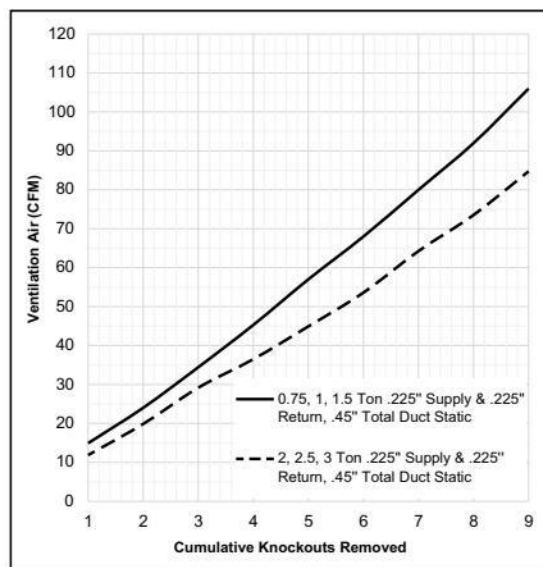

## WALL SLEEVES &amp; LOUVERS

Wall Sleeves		Louvers			Model						Dimensions (in.)			
Wall Sleeve	Wall Sleeve Extension	Polypropylene Louvers	Aluminum Louvers	Impact Louvers	MCE-7-11-09-P	MCE-7-11-12-P	MCE-7-11-18-P	MCE-7-11-24-P	MCE-7-11-30-P	MCE-7-13-36-P	Wall Sleeve	Wall Opening		
											Height (A)	Height (B)	Sleeve Only	Sleeve Plus Extension
ASLEEVE6-1	---	ALVRP***-1	ALVRAL-1*	ALVRALC-1*	•	•	•	•			29	29-1/8		
ASLEEVE8-1	---	ALVRP***-1	ALVRAL-1*	ALVRALC-1*	•	•	•	•			29	29-1/8	8	---
ASLEEVE10-1	ASLEEVEEXT4-1	ALVRP***-1	ALVRAL-1*	ALVRALC-1*	•	•	•	•			29	29-1/8	10	14
ASLEEVE12-1	ASLEEVEEXT4-1	ALVRP***-1	ALVRAL-1*	ALVRALC-1*	•	•	•	•			29	29-1/8	12	16
ASLEEVE6-2	---	ALVRP***-2	ALVRAL-2*	ALVRALC-2*					•		32-3/4	32-7/8	6	---
ASLEEVE8-2	---	ALVRP***-2	ALVRAL-2*	ALVRALC-2*					•		32-3/4	32-7/8	8	---
ASLEEVE10-2	ASLEEVEEXT4-2	ALVRP***-2	ALVRAL-2*	ALVRALC-2*					•		32-3/4	32-7/8	10	14
ASLEEVE12-2	ASLEEVEEXT4-2	ALVRP***-2	ALVRAL-2*	ALVRALC-2*					•		32-3/4	32-7/8	12	16
ASLEEVE6-2	---	ALVRP***-2	ALVRAL-7*	ALVRALC-7*	○	○	○	○			32-3/4	32-7/8	6	---
ASLEEVE8-2	---	ALVRP***-2	ALVRAL-7*	ALVRALC-7*	○	○	○	○			32-3/4	32-7/8	8	---
ASLEEVE10-2	ASLEEVEEXT4-2	ALVRP***-2	ALVRAL-7*	ALVRALC-7*	○	○	○	○			32-3/4	32-7/8	10	14
ASLEEVE12-2	ASLEEVEEXT4-2	ALVRP***-2	ALVRAL-7*	ALVRALC-7*	○	○	○	○			32-3/4	32-7/8	12	16
ASLEEVE6-5	---	ALVRP***-3	---	---	○	○	○	○	○	•	45	45-1/8	6	---
ASLEEVE8-5	---	ALVRP***-3	---	---	○	○	○	○	○	•	45	45-1/8	8	---
ASLEEVE10-5	ASLEEVEEXT4-3	ALVRP***-3	---	---	○	○	○	○	○	•	45	45-1/8	10	14
ASLEEVE12-5	ASLEEVEEXT4-3	ALVRP***-3	---	---	○	○	○	○	○	•	45	45-1/8	12	16
ASLEEVE6-5	---	---	ALVRAL-3*	ALVRALC-3*	○	○	○	○			45	45-1/8	6	---
ASLEEVE8-5	---	---	ALVRAL-3*	ALVRALC-3*	○	○	○	○			45	45-1/8	8	---
ASLEEVE10-5	ASLEEVEEXT4-3	---	ALVRAL-3*	ALVRALC-3*	○	○	○	○			45	45-1/8	10	14
ASLEEVE12-5	ASLEEVEEXT4-3	---	ALVRAL-3*	ALVRALC-3*	○	○	○	○			45	45-1/8	12	16
ASLEEVE6-5	---	---	ALVRAL-4*	ALVRALC-4*					○	•	45	45-1/8	6	---
ASLEEVE8-5	---	---	ALVRAL-4*	ALVRALC-4*					○	•	45	45-1/8	8	---
ASLEEVE10-5	ASLEEVEEXT4-3	---	ALVRAL-4*	ALVRALC-4*					○	•	45	45-1/8	10	14
ASLEEVE12-5	ASLEEVEEXT4-3	---	ALVRAL-4*	ALVRALC-4*					○	•	45	45-1/8	12	16

Note: Wall Sleeve and Louver size must be coordinated

\*\*\* Louver colors: WHT = white, SAN = sandstone, BGE = beige, TPST = taupestone

\*-P: Option to paint standard, aluminum, and impact-resistant louvers

• Wall sleeve and louver sizes equal to the required wall opening dimensions for the unit size

○ Optional: Wall sleeves and louvers can be oversized to maintain a uniform appearance

## WALL SLEEVE &amp; WALL OPENING DIMENSIONS (IN.)

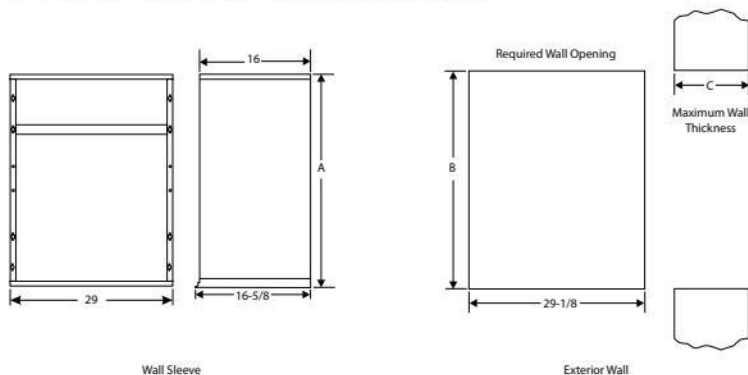

**SCCR ACCESSORY**

Model	Kit <sup>1</sup>
MCE0-7-11-09*P	ASCCR1
MCE3-7-11-09*P	
MCE5-7-11-09*P	ASCCR2
MCE0-7-11-12*P	ASCCR1
MCE3-7-11-12*P	
MCE5-7-11-12*P	ASCCR2
MCE0-7-11-18*P	ASCCR1
MCE3-7-11-18*P	
MCE5-7-11-18*P	ASCCR2
MCE7-7-11-18*P	ASCCR3
MCE10-7-11-18*P	ASCCR5
MCE0-7-11-24*P	ASCCR1
MCE5-7-11-24*P	ASCCR2
MCE7-7-11-24*P	ASCCR3
MCE10-7-11-24*P	ASCCR5
MCE0-7-11-30*P	ASCCR2
MCE5-7-11-30*P	
MCE7-7-11-30*P	ASCCR3
MCE10-7-11-30*P	ASCCR5
MCE0-7-13-36*P	ASCCR3
MCE5-7-13-36*P	
MCE7-7-13-36*P	
MCE10-7-13-36*P	ASCCR5

**CRANKCASE HEATER**

Model	Kit
MCE*-7-11-09*P	N/A
MCE*-7-11-12*P	
MCE*-7-11-18*P	
MCE*-7-11-24*P	ACASE841
MCE*-7-11-30*P	
MCE*-7-13-36*P	

**REFRIGERANT DETECTION SYSTEM KIT (RDS)**

Model	Kit
MCE*-7-11-09*P <sup>1</sup>	ARDSKTM
MCE*-7-11-12*P <sup>1</sup>	
MCE*-7-11-18*P <sup>1</sup>	
MCE*-7-11-24*P <sup>2</sup>	
MCE*-7-11-30*P <sup>2</sup>	
MCE*-7-13-36*P <sup>2</sup>	

<sup>1</sup> Field-installed RDS in a Free-Air Return Application

<sup>2</sup> Factory-installed RDS

Additional RDS kits are available for field installation.

<sup>1</sup> Per UL 508A, 200kA RMS Symmetrical

## RATED COOLING & HEATING PERFORMANCE

Tonnage	Model	Cooling			Electric Heat					
		Net Capacity (Btu/hr)	Efficiency SEER2/EER2	S/T <sup>†</sup>	240V		230V		208V	
					kW	BTU/hr	kW	BTU/hr	kW	BTU/hr
0.75	MCE0-7-11-09*	8,600	11.7/10.5	0.75	N/A	N/A	N/A	N/A	N/A	N/A
	MCE3-7-11-09*				3.6	12,284	3.31	11,281	2.70	9,226
	MCE5-7-11-09*				4.8	16,378	4.41	15,042	3.61	12,302
1.0	MCE0-7-11-12*	12,000	11.7/10.0	0.72	N/A	N/A	N/A	N/A	N/A	N/A
	MCE3-7-11-12*				3.6	12,284	3.31	11,281	2.70	9,226
	MCE5-7-11-12*				4.8	16,378	4.41	15,042	3.61	12,302
1.5	MCE0-7-11-18*	16,800	11.7/10.0	0.78	N/A	N/A	N/A	N/A	N/A	N/A
	MCE3-7-11-18*				3.6	12,284	3.31	11,281	2.70	9,226
	MCE5-7-11-18*				4.8	16,378	4.41	15,042	3.61	12,302
	MCE7-7-11-18*				7.2	24,567	6.61	22,563	5.41	18,453
	MCE10-7-11-18*				9.6	32,757	8.82	30,084	7.21	24,604
2.0	MCE0-7-11-24*	22,200	11.7/10.5	0.75	N/A	N/A	N/A	N/A	N/A	N/A
	MCE5-7-11-24*				4.8	16,378	4.41	15,042	3.61	12,302
	MCE7-7-11-24*				7.2	24,567	6.61	22,563	5.41	18,453
	MCE10-7-11-24*				9.6	32,757	8.82	30,084	7.21	24,604
2.5	MCE0-7-11-30*	28,000	11.7/10.5	0.77	N/A	N/A	N/A	N/A	N/A	N/A
	MCE5-7-11-30*				4.8	16,378	4.41	15,042	3.61	12,302
	MCE7-7-11-30*				7.2	24,567	6.61	22,563	5.41	18,453
	MCE10-7-11-30*				9.6	32,757	8.82	30,084	7.21	24,604
3.0	MCE0-7-13-36*	34,800	13.4/10.6	0.73	N/A	N/A	N/A	N/A	N/A	N/A
	MCE5-7-13-36*				4.8	16,378	4.41	15,042	3.61	12,302
	MCE7-7-13-36*				7.2	24,567	6.61	22,563	5.41	18,453
	MCE10-7-13-36*				9.6	32,757	8.82	30,084	7.21	24,604

\* Not a rated value.

† Two-stage heat available for 7kW and 10kW units

S/T = ratio of sensible to total cooling load

For most up to date ratings and values, please view AHRI listing

## EXTENDED COOLING PERFORMANCE DATA

Tonnage	Model	Indoor Temp DB/WB (°F)	Outdoor Temperature - DB (°F)														
			65			85			95			105			115		
			Net Capacity (Btu/hr)	S/T	System Power Input (kW)	Net Capacity (Btu/hr)	S/T	System Power Input (kW)	Net Capacity (Btu/hr)	S/T	System Power Input (kW)	Net Capacity (Btu/hr)	S/T	System Power Input (kW)	Net Capacity (Btu/hr)	S/T	System Power Input (kW)
0.75	MCE-7-11-09-P	85/72	10490	0.56	0.72	10390	0.65	0.81	10040	0.66	0.87	9570	0.71	0.95	9100	0.76	1.03
		80/67	10110	0.66	0.68	10010	0.77	0.80	9370	0.76	0.86	8830	0.81	0.94	8290	0.86	1.02
		75/63	9410	0.70	0.68	9260	0.78	0.80	8820	0.81	0.86	8130	0.86	0.93	7440	0.90	1.01
		75/57	9040	1.00	0.68	8940	1.00	0.79	8150	1.00	0.86	7730	1.00	0.93	7300	1.00	1.00
1.0	MCE-7-11-12-P	85/72	13770	0.59	0.88	13600	0.62	1.06	13180	0.64	1.16	12400	0.67	1.26	11740	0.70	1.38
		80/67	13210	0.65	0.87	12790	0.69	1.05	12400	0.72	1.15	11500	0.75	1.25	10580	0.77	1.37
		75/63	12690	0.69	0.87	12160	0.72	1.04	11640	0.75	1.14	10740	0.78	1.24	9910	0.81	1.35
		75/57	11560	1.00	0.87	11220	1.00	1.04	10790	1.00	1.13	10280	1.00	1.23	9210	1.00	1.34
1.5	MCE-7-11-18-P	85/72	19440	0.63	1.12	18590	0.67	1.37	18030	0.71	1.51	17100	0.75	1.66	15940	0.79	1.84
		80/67	18720	0.71	1.12	17770	0.75	1.36	16540	0.80	1.51	15730	0.83	1.65	14330	0.87	1.82
		75/63	17780	0.76	1.12	16640	0.80	1.36	15660	0.83	1.49	14400	0.86	1.64	12950	0.91	1.80
		75/57	16620	1.00	1.11	16190	1.00	1.35	14970	1.00	1.48	14000	1.00	1.62	12460	1.00	1.77
2.0	MCE-7-11-24-P	85/72	26340	0.60	1.54	26050	0.65	1.88	24970	0.68	2.08	23410	0.71	2.28	21420	0.76	2.51
		80/67	25170	0.68	1.54	24370	0.73	1.87	22910	0.77	2.06	21040	0.80	2.26	18880	0.85	2.48
		75/63	24150	0.71	1.54	22880	0.77	1.86	21180	0.80	2.04	19220	0.83	2.23	17200	0.88	2.43
		75/57	22430	1.00	1.53	21680	1.00	1.85	19690	1.00	2.03	18640	1.00	2.21	16390	1.00	2.42
2.5	MCE-7-11-30-P	85/72	31580	0.60	1.94	31180	0.64	2.36	30710	0.67	2.60	28990	0.71	2.89	27190	0.75	3.21
		80/67	30290	0.66	1.93	29500	0.73	2.35	28710	0.76	2.63	26690	0.80	2.86	24360	0.84	3.19
		75/63	29290	0.70	1.92	27890	0.77	2.35	26550	0.80	2.58	24570	0.82	2.85	22350	0.86	3.15
		75/57	26930	1.00	1.93	25940	1.00	2.35	24290	1.00	2.58	23780	1.00	2.83	21740	1.00	3.13
3.0	MCE-7-13-36-P	85/72	41870	0.61	2.28	39490	0.65	2.74	38460	0.66	3.10	36340	0.69	3.35	34080	0.71	3.72
		80/67	39740	0.68	2.27	37350	0.72	2.73	35150	0.73	3.01	33630	0.76	3.33	31350	0.80	3.67
		75/63	37890	0.72	2.27	35270	0.75	2.71	33550	0.77	3.04	31410	0.79	3.30	28700	0.83	3.63
		75/57	34750	1.00	2.21	33770	1.00	2.69	31930	1.00	2.96	29900	1.00	3.26	27540	1.00	3.60

NOTE: Values based on 0.3" w.c. external static pressure except for MCE-7-13-36-P, which is based on 0.5" w.c. external static pressure

## BLOWER PERFORMANCE

- Performance based on factory-provided washable filter installed in the unit.
- If a higher resistance filter is field installed in the unit, the added resistance must be included in the external static pressure and must not exceed 0.5 in. w.c. including ductwork
- Refer to Factory Filter Size and Pressure Drop table for additional details

SUPPLY AIRFLOW PERFORMANCE AS A FUNCTION OF EXTERNAL STATIC PRESSURE																		
Tonnage	Model	Indoor Blower Speed	0.1" w.c.			0.2" w.c.			0.3" w.c.			0.4" w.c.			0.5" w.c.			
			SCFM	Watts	HP	SCFM	Watts	HP	SCFM	Watts	HP	SCFM	Watts	HP	SCFM	Watts	HP	
0.75	MCE-7-11-09-P	TAP 1 (FAN)	355	28	0.04	320	31	0.04	275	35	0.05	230	38	0.05	160	42	0.06	
		TAP 2 (COOL)	375	31	0.04	330	33	0.04	285	37	0.05	N/A	N/A	N/A	N/A	N/A	N/A	
		TAP 3 (COOL)*	N/A	N/A	N/A	N/A	N/A	N/A	355	36	0.05	315	40	0.05	280	43	0.06	
		0 kW	TAP 4 (HEAT)*	375	31	0.04	330	33	0.04	285	37	0.05	240	40	0.05	180	44	0.06
			TAP 5 (HEAT)	465	47	0.06	425	51	0.07	390	55	0.07	370	58	0.08	330	62	0.08
		3 kW	TAP 4 (HEAT)*	430	41	0.05	410	45	0.06	385	49	0.07	N/A	N/A	N/A	N/A	N/A	N/A
			TAP 5 (HEAT)	520	58	0.08	500	63	0.08	475	68	0.09	440	73	0.10	400	77	0.10
		5 kW	TAP 4 (HEAT)*	525	59	0.08	505	65	0.09	480	69	0.09	N/A	N/A	N/A	N/A	N/A	N/A
			TAP 5 (HEAT)	615	81	0.11	590	88	0.12	560	94	0.13	530	99	0.13	500	103	0.14
		1.0	MCE-7-11-12-P	TAP 1 (FAN)	355	28	0.04	320	31	0.04	275	35	0.05	230	38	0.05	160	42
TAP 2 (COOL)	420			40	0.05	380	42	0.06	355	46	0.06	N/A	N/A	N/A	N/A	N/A	N/A	
TAP 3 (COOL)*	N/A			N/A	N/A	435	51	0.07	395	55	0.07	355	59	0.08	320	63	0.08	
0 kW	TAP 4 (HEAT)*			420	40	0.05	380	42	0.06	355	46	0.06	315	50	0.07	275	54	0.07
	TAP 5 (HEAT)			515	58	0.08	480	62	0.08	445	66	0.09	415	70	0.09	380	74	0.10
3 kW	TAP 4 (HEAT)*			430	41	0.05	410	45	0.06	385	49	0.07	N/A	N/A	N/A	N/A	N/A	N/A
	TAP 5 (HEAT)			520	58	0.08	500	63	0.08	475	68	0.09	440	73	0.10	400	77	0.10
5 kW	TAP 4 (HEAT)*			525	59	0.08	505	65	0.09	480	69	0.09	N/A	N/A	N/A	N/A	N/A	N/A
	TAP 5 (HEAT)			615	81	0.11	590	88	0.12	560	94	0.13	530	99	0.13	500	103	0.14

N/A: Do not operate unit using this blower speed at this external static pressure.

\* As shipped speed for Cooling operation. Blower speed must be field adjusted to Speed Tap 2 for lower duct static applications.

\* As shipped speed for Heating operation. Blower speed must be field adjusted to Speed Tap 5 for higher duct static applications.

SCFM = standard cubic feet per minute

## BLOWER PERFORMANCE CONTINUED

- Performance based on factory-provided washable filter installed in the unit.
- If a higher resistance filter is field installed in the unit, the added resistance must be included in the external static pressure and must not exceed 0.5 in. w.c. including ductwork
- Refer to Factory Filter Size and Pressure Drop table for additional details

SUPPLY AIRFLOW PERFORMANCE AS A FUNCTION OF EXTERNAL STATIC PRESSURE																		
Tonnage	Model	Indoor Blower Speed	0.1" w.c.			0.2" w.c.			0.3" w.c.			0.4" w.c.			0.5" w.c.			
			SCFM	Watts	HP	SCFM	Watts	HP	SCFM	Watts	HP	SCFM	Watts	HP	SCFM	Watts	HP	
1.5	MCE-7-11-18*P	TAP 1 (FAN)	355	28	0.04	320	31	0.04	275	35	0.05	230	38	0.05	160	42	0.06	
		TAP 2 (COOL)	660	103	0.14	640	109	0.15	610	114	0.15	580	119	0.16	550	124	0.17	
		TAP 3 (COOL)*	705	115	0.15	680	121	0.16	660	125	0.17	635	131	0.18	610	135	0.18	
		0 kW	TAP 4 (HEAT)*	660	103	0.14	640	109	0.15	610	114	0.15	580	119	0.16	550	124	0.17
			TAP 5 (HEAT)	725	131	0.18	710	135	0.18	685	140	0.19	660	146	0.20	640	152	0.20
		3 kW	TAP 4 (HEAT)*	430	41	0.05	410	45	0.06	385	49	0.07	N/A	N/A	N/A	N/A	N/A	N/A
			TAP 5 (HEAT)	520	59	0.08	500	63	0.08	475	67	0.09	440	72	0.10	400	77	0.10
		5 kW	TAP 4 (HEAT)*	525	60	0.08	505	65	0.09	480	70	0.09	N/A	N/A	N/A	N/A	N/A	N/A
			TAP 5 (HEAT)	615	81	0.11	590	88	0.12	560	95	0.13	530	100	0.13	500	103	0.14
		7 kW	TAP 4 (HEAT)*	685	108	0.14	670	116	0.16	645	122	0.16	N/A	N/A	N/A	N/A	N/A	N/A
			TAP 5 (HEAT)	N/A	N/A	N/A	770	160	0.21	750	166	0.22	720	172	0.23	700	177	0.24
		10 kW	TAP 4 (HEAT)*	N/A	N/A	N/A	770	160	0.21	750	166	0.22	N/A	N/A	N/A	N/A	N/A	N/A
			TAP 5 (HEAT)	N/A	N/A	N/A	N/A	N/A	N/A	N/A	N/A	N/A	820	226	0.30	800	230	0.31

N/A: Do not operate unit using this blower speed at this external static pressure.

\* As shipped speed for Cooling operation. Blower speed must be field adjusted to Speed Tap 2 for lower duct static applications.

\* As shipped speed for Heating operation. Blower speed must be field adjusted to Speed Tap 5 for higher duct static applications.

SCFM = standard cubic feet per minute

## BLOWER PERFORMANCE CONTINUED

- Performance based on factory-provided washable filter installed in the unit.
- If a higher resistance filter is field installed in the unit, the added resistance must be included in the external static pressure and must not exceed 0.5 in. w.c. including ductwork
- Refer to Factory Filter Size and Pressure Drop table for additional details

SUPPLY AIRFLOW PERFORMANCE AS A FUNCTION OF EXTERNAL STATIC PRESSURE																		
Tonnage	Model	Indoor Blower Speed	0.1" w.c.			0.2" w.c.			0.3" w.c.			0.4" w.c.			0.5" w.c.			
			SCFM	Watts	HP	SCFM	Watts	HP	SCFM	Watts	HP	SCFM	Watts	HP	SCFM	Watts	HP	
2.0	MCE-7-11-24-P	TAP 1 (FAN)	455	41	0.05	420	45	0.06	385	49	0.07	365	52	0.07	320	57	0.08	
		TAP 2 (COOL)	810	146	0.20	790	158	0.21	780	166	0.22	755	173	0.23	735	179	0.24	
		TAP 3 (COOL)*	850	177	0.24	830	184	0.25	810	190	0.25	785	197	0.26	760	199	0.27	
		0 kW	TAP 4 (HEAT)*	810	146	0.20	790	158	0.21	780	166	0.22	755	173	0.23	735	179	0.24
			TAP 5 (HEAT)	870	179	0.24	860	184	0.25	845	194	0.26	815	202	0.27	785	206	0.28
		5 kW	TAP 4 (HEAT)*	555	65	0.09	540	69	0.09	510	73	0.10	480	76	0.10	N/A	N/A	N/A
			TAP 5 (HEAT)	645	88	0.12	630	94	0.13	605	100	0.13	580	105	0.14	550	110	0.15
		7 kW	TAP 4 (HEAT)*	775	140	0.19	765	145	0.19	745	150	0.20	725	154	0.21	N/A	N/A	N/A
			TAP 5 (HEAT)	875	184	0.25	865	193	0.26	845	201	0.27	825	208	0.28	800	215	0.29
		10 kW	TAP 4 (HEAT)*	875	184	0.25	865	193	0.26	845	201	0.27	825	208	0.28	N/A	N/A	N/A
			TAP 5 (HEAT)	N/A	N/A	N/A	N/A	N/A	N/A	N/A	N/A	N/A	960	272	0.36	900	276	0.37
		2.5	MCE-7-11-30-P	TAP 1 (FAN)	590	42	0.06	530	48	0.06	430	55	0.07	380	60	0.08	315	65
TAP 2 (COOL)	1015			152	0.20	985	161	0.22	940	170	0.23	910	177	0.24	875	184	0.25	
TAP 3 (COOL)*	N/A			N/A	N/A	N/A	N/A	N/A	1000	219	0.29	970	227	0.30	950	235	0.32	
0 kW	TAP 4 (HEAT)*			1015	152	0.20	985	161	0.22	940	170	0.23	910	177	0.24	875	184	0.25
	TAP 5 (HEAT)			N/A	N/A	N/A	N/A	N/A	N/A	N/A	N/A	N/A	1015	219	0.29	980	227	0.30
5 kW	TAP 4 (HEAT)*			740	65	0.09	705	74	0.10	640	83	0.11	N/A	N/A	N/A	N/A	N/A	N/A
	TAP 5 (HEAT)			820	81	0.11	790	91	0.12	740	100	0.13	675	109	0.15	600	117	0.16
7 kW	TAP 4 (HEAT)*			860	91	0.12	835	100	0.13	795	108	0.14	N/A	N/A	N/A	N/A	N/A	N/A
	TAP 5 (HEAT)			945	112	0.15	925	122	0.16	885	132	0.18	845	140	0.19	800	148	0.20
10 kW	TAP 4 (HEAT)*			945	112	0.15	925	122	0.16	885	132	0.18	N/A	N/A	N/A	N/A	N/A	N/A
	TAP 5 (HEAT)			N/A	N/A	N/A	N/A	N/A	N/A	980	161	0.22	940	170	0.23	900	179	0.24

N/A: Do not operate unit using this blower speed at this external static pressure.

\* As shipped speed for Cooling operation. Blower speed must be field adjusted to Speed Tap 2 for lower duct static applications.

\* As shipped speed for Heating operation. Blower speed must be field adjusted to Speed Tap 5 for higher duct static applications.

SCFM = standard cubic feet per minute

## BLOWER PERFORMANCE CONTINUED

- Performance based on factory-provided washable filter installed in the unit.
- If a higher resistance filter is field installed in the unit, the added resistance must be included in the external static pressure and must not exceed 0.5 in. w.c. including ductwork
- Refer to Factory Filter Size and Pressure Drop table for additional details

SUPPLY AIRFLOW PERFORMANCE AS A FUNCTION OF EXTERNAL STATIC PRESSURE																		
Tonnage	Model	Indoor Blower Speed	0.1" w.c.			0.2" w.c.			0.3" w.c.			0.4" w.c.			0.5" w.c.			
			SCFM	Watts	HP	SCFM	Watts	HP	SCFM	Watts	HP	SCFM	Watts	HP	SCFM	Watts	HP	
3.0	MCE-7-13-36-P	TAP 1 (FAN)	680	61	0.08	630	68	0.09	575	74	0.10	525	79	0.11	460	86	0.12	
		TAP 2 (COOL)	1235	260	0.35	1200	272	0.36	1166	284	0.38	1135	295	0.40	1100	305	0.41	
		TAP 3 (COOL)*	N/A	N/A	N/A	N/A	N/A	N/A	1240	302	0.40	1220	314	0.42	1195	326	0.44	
		0 kW	TAP 4 (HEAT)*	1235	260	0.35	1200	272	0.36	1166	284	0.38	1135	295	0.40	1100	305	0.41
			TAP 5 (HEAT)	N/A	N/A	N/A	N/A	N/A	N/A	1250	330	0.44	1215	342	0.46	1180	354	0.47
		5 kW	TAP 4 (HEAT)*	740	75	0.10	695	82	0.11	640	90	0.12	N/A	N/A	N/A	N/A	N/A	N/A
			TAP 5 (HEAT)	815	92	0.12	785	100	0.13	745	108	0.14	700	115	0.15	650	122	0.16
		7 kW	TAP 4 (HEAT)*	815	92	0.12	785	100	0.13	745	108	0.14	N/A	N/A	N/A	N/A	N/A	N/A
			TAP 5 (HEAT)	910	117	0.16	880	126	0.17	840	135	0.18	800	143	0.19	750	150	0.20
		10 kW	TAP 4 (HEAT)*	1010	143	0.19	980	155	0.21	945	166	0.22	N/A	N/A	N/A	N/A	N/A	N/A
			TAP 5 (HEAT)	1085	175	0.23	1065	187	0.25	1030	198	0.27	995	209	0.28	950	219	0.29

N/A: Do not operate unit using this blower speed at this external static pressure.

\* As shipped speed for Cooling operation. Blower speed must be field adjusted to Speed Tap 2 for lower duct static applications.

\* As shipped speed for Heating operation. Blower speed must be field adjusted to Speed Tap 5 for higher duct static applications.

SCFM = standard cubic feet per minute



215 Metropolitan Drive | West Columbia, SC 29170  
800-448-5872

Product Support 866-282-7257  
www.magic-pak.com

All specifications and illustrations subject to change  
without notice and without incurring obligations