



## Product Data Sheet

Ceiling Suspended (without ERV option)



## CONTACT INFO

### Flagship Showroom

+1 (212) 244-1100  
106 W. 56th Street  
4th Floor  
New York, NY 10019

### Corporate HQ

+1 (216) 710-1000  
1111 Superior Ave  
Suite 620  
Cleveland, OH 44144

[info@ephoca.com](mailto:info@ephoca.com)

[www.ephoca.com](http://www.ephoca.com)

[www.aioair.com](http://www.aioair.com)

## DISCLAIMER

This documentation is intended for informational use only and should not be construed as a binding representation or contract. This documentation is provided "as is" without warranty of any kind, either express or implied. Ephoca and its affiliates disclaim all liability arising from the use or misuse of this documentation.

Illustrations may not be to scale, and all information and dimensions stated herein are subject to change at any time at the sole discretion of Ephoca. Benefits described herein apply only to the extent that the product is installed correctly in the correct application and used for its intended purpose.

Ephoca is constantly innovating and improving its products and reserves the right to modify product design and specifications without notice, and without incurring any obligations.

## MODEL NUMBER NOMENCLATURE

The code identifies the family, model, version, size, voltage, accessories, refrigerant type, and ERV option. See the diagram below for details.

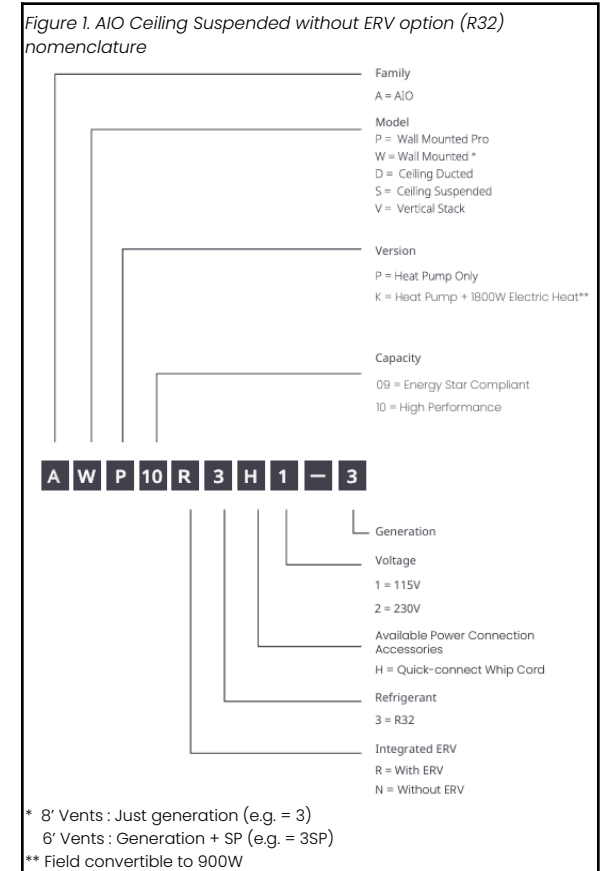

AIO® is a registered trademark of Ephoca

Ephoca is the US subsidiary of INNOVA S.r.l  
Via 1° Maggio, 8 – 38089 Storo (TN), Italy.

Copyright © 2026 Ephoca. All rights reserved.



# CONTENTS

<b>1. READING THIS DOCUMENTATION.....</b>	<b>4</b>
1.1 Documentation-specific language.....	4
1.2 Annotation icons.....	4
<b>2. AIO CEILING SUSPENDED – (WITHOUT ERV OPTION) OVERVIEW.....</b>	<b>4</b>
2.1 Components and structure.....	4
2.2 Key features.....	5
<b>3. AIRFLOW.....</b>	<b>5</b>
<b>4. INSTALLATION.....</b>	<b>6</b>
4.1 Air Balancing Requirements.....	6
4.2 Low Ambient Heating Configuration Requirement.....	6
4.3 Cold Climate Condensate Drain Requirement	6
4.4 Ambient Temperature Protection.....	6
4.5 Site requirements.....	6
4.6 Louver specifications.....	7
4.7 Minimum installation distances.....	7
<b>5. TECHNICAL SPECIFICATIONS.....</b>	<b>8</b>
5.1 High Performance.....	8
5.1.1 Cooling.....	8
5.1.2 Heating – Heat pump only.....	8
5.2 Energy Star Compliant.....	9
5.2.1 Cooling.....	9
5.2.2 Heating – Heat pump only.....	9
5.3 Airflow.....	9
5.3.1 Indoor.....	9
5.3.2 Outdoor.....	9
5.4 Sound.....	9
5.5 General.....	10
5.5.1 Controls.....	10
5.5.2 Modes.....	10
5.5.3 Condensate.....	10
5.5.4 Compressor.....	10
5.5.5 Physical data.....	10
5.6 Electrical.....	10
5.6.1 General.....	10
5.6.2 Compressor.....	10
5.6.3 Circuit breakers.....	10
5.6.4 LCDI power cords.....	10
<b>6. WIRING DIAGRAM.....</b>	<b>11</b>
6.1 Notes.....	11
<b>7. DIMENSIONS.....</b>	<b>11</b>
<b>8. MOUNTING TEMPLATE.....</b>	<b>12</b>
<b>9. WARRANTY.....</b>	<b>12</b>
9.1 Basic Coverage.....	12
9.2 Optional Extended Coverage.....	12
9.3 Validation Requirements.....	12
<b>10. SUBMITTALS.....</b>	<b>13</b>
10.1 115V Heat pump only – High Performance.....	13
10.2 115V Heat pump + elec heat – High Performance.....	14
10.3 230V Heat pump only – High Performance.....	15
10.4 230V Heat pump + elec heat – High Performance.....	16
10.5 115V Heat pump only – Energy Star Compliant.....	17
10.6 115V Heat pump + elec heat – Energy Star Compliant.....	18
10.7 230V Heat pump only – Energy Star Compliant.....	19
10.8 230V Heat pump + elec heat – Energy Star Compliant.....	20



## 1. READING THIS DOCUMENTATION

Some language and symbols in this documentation have specific meanings.

### 1.1 Documentation-specific language

#### Reference to the product

Any reference to “the unit” refers to the AIO Ceiling Suspended without ERV option (R32) unit.

#### Unit orientation

All directions in this guide (left, right, top, bottom) are given from the perspective of facing the unit.

### 1.2 Annotation icons

Annotations are provided throughout this guide. It is essential to read each carefully and follow the instructions stated.



Indicates critical information for correct operation or installation.



Indicates supplemental information, tips, or useful background information.

## 2. AIO CEILING SUSPENDED – (WITHOUT ERV OPTION) OVERVIEW

AIO Ceiling Suspended can be discreetly installed above a ceiling and is ideal for single or multi-room applications. The return can be from the sides or the bottom for maximum flexibility. With up to 0.45” (11.4 mm) external static pressure, this unit can be used where ducting is required. Use with any interior grille and louver to provide additional design flexibility.

## 2.1 Components and structure

Figure 2. What's Inside

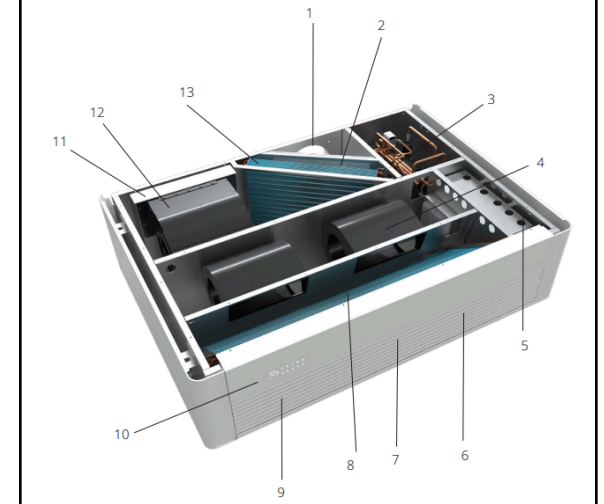

1	Condenser air intake	8	High-efficiency indoor coil
2	High efficiency outdoor coil	9	Bottom return
3	Twin rotary inverter compressor	10	Touch controller
4	ECM centrifugal supply fan	11	Condensate exhaust
5	Electrical controls	12	ECM condenser fan
6	Supply air grille	13	Condensate drain
7	Resistant heat strip		

## 2.2 Key features

### No outdoor unit

The single package design means that there is no outdoor unit, freeing up space on rooftops and at ground level and enabling installations in buildings without space for an outdoor unit.

### Twin rotary BLDC inverter compressor

The state-of-the-art, twin rotary Brushless DC (BLDC) inverter compressor operates efficiently, quietly, and with minimal vibration. AIO's Ceiling Suspended unit is ideal for any room or area that requires between 4,000 and 10,500 BTU/h.

### High-efficiency ECM fans with auto ESP

High-efficiency electronically commutated motor (ECM) fans enable efficient and quiet operation because the EC motor can ramp up or down as needed. Automatically adjusted external static pressure ensures correct airflow.

### Cold climate heat pump

The heat pump operates at full efficiency when outdoor temperatures are as low as 5°F (-15°C), and will still operate at colder temperatures below -5°F (-20.6°C).

The optional electric heating system operates alongside the heat pump when the latter lacks adequate power. This electric heating setup consists of two 900W heaters, strategically staged to optimize efficiency while minimizing the use of electric heat. The unit offers configuration options for electric heat usage: it can be set to use no electric heat, 900W electric heat, or 1,800W electric heat, providing flexibility and energy management capabilities.

### Intelligent defrosting

AIO's intelligent defrosting system means more time heating and less time on reverse cycle defrost

### Quiet

With whisper-quiet operation as low as 27 decibels, the occupant will barely notice that the AIO Ceiling Suspended unit is operating.

### Versatile on/off options

AIO's low-voltage connection enables connection to any Building Management System (BMS), key-card

system, window sensors, fire alarms, etc. As long as a system can send a signal to the AIO unit via low voltage, the unit can be easily turned on or off.

### Corrosion protection

AIO comes standard with corrosion protection, assuring many years of trouble-free performance.

### Minimal clearances and compact footprint

AIO's compact form does not use any line sets. This means that there is no need to access the sides of the unit. You can mount units with as little as 3/4" (19.1 mm) clearance on all sides.

### Leak protection

If a drain becomes clogged, the system shuts down and an alarm is activated. This prevents water damage.

### Easy to service

The AIO unit can be easily maintained and repaired from the front or bottom of the unit without having to remove the unit from the wall. An AIO unit can also be quickly swapped with a replacement, reducing downtime.

### Versatile controls

The AIO unit includes an onboard touch controller and an optional iOS and Android app. AIO can be used with optional wall-mounted controllers, including a Thin Film Transistor (TFT) with a 7-day program, and third-party controllers from any company, using the optional third-party kit. An optional BACnet and Modbus module enables interfacing with building management systems.

### 10-Year limited warranty

An industry-leading 10-year limited warranty provides peace of mind.

- Comprehensive onsite two-year parts and labor (after certification).
- 5-year parts warranty.
- 10-year parts warranty on the compressor.

See [Warranty Terms and Conditions](#) for details.

## 3. AIRFLOW

The AIO Ceiling Suspended unit is flexible in many ways. This flexibility enables AIO Ceiling Suspended to be placed anywhere in a dwelling without restrictions.

### • Supply air

The supply air is through the fixed front louver.

### • Stale air exhaust

The room air and exhaust air are returned to the unit through the integrated return air grille on the bottom of the unit.

### • Return air

For optimal performance, a fully ducted return configuration is recommended. Both return air openings must remain open and unobstructed during operation. The unit may be installed with both returns ducted, or with one return ducted and the other left open as a side plenum return.

### • Outside air intake

Air for the condenser portion. This can be ducted with up to 0.45" WC (112.1 Pa) external static pressure (combined between intake and exhaust).

### • Outside air exhaust

The single 6" (152.4 mm) round outside air exhaust connection is for the condenser portion. This can be ducted with up to 0.45" WC (112.1 Pa) external static pressure (combined between intake and exhaust).

Figure 3. Airflow

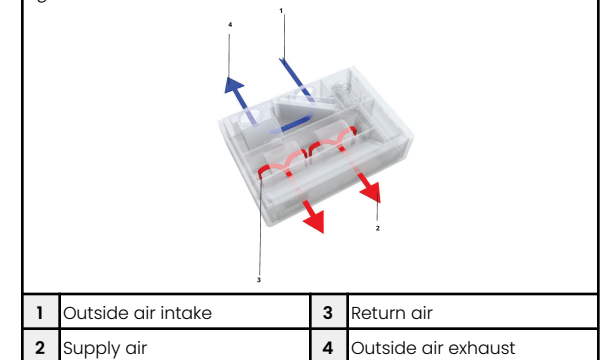

## 4. INSTALLATION

Figure 4. Installation



Figure 5. Ducted external vent and Direct existing window vent



Figure 6. Shared supply and exhaust vents





### 4.1. Air Balancing Requirements

- All units must be properly air balanced by a qualified, professional air balancing company.
- Air balancing must be performed after installation and prior to final commissioning.
- A formal air balancing report must be completed and made available.
- Failure to perform air balancing properly may result in improper performance, system issues, and voiding of the warranty.

### 4.2 Low Ambient Heating Configuration Requirement

To configure the unit for electric resistance heating in low ambient conditions:

1. Turn on the unit.
2. Press and hold  for 10 seconds until “Fh” appears on the display.
3. Press and hold  for 5-10 seconds until “Fo” appears on the display.
4. Press and hold  for 5-10 seconds until “rE” appears on the display.
5. Wait a few seconds (without pressing any buttons) to exit the menu.

rE = Resistance heat mode

This setting switches the unit to electric resistance heating during low ambient conditions, preventing heat pump operation that may contribute to ice formation.

### 4.3 Cold Climate Condensate Drain Requirement

For installations in cold or northern climates, a condensate drain line heater is required.

Use of a drain line heater is standard industry practice and is necessary to prevent condensate freezing during low ambient operation. Failure to install a drain line heater may result in ice formation and improper unit operation.

Abnormally low ambient temperatures may increase the risk of freezing even when the unit is properly configured.

### 4.4 Ambient Temperature Protection

When installed in climates with extreme ambient temperatures, the unit must be located in an enclosed, temperature-protected indoor space that will not reach less than 5°F (-15°C).

### 4.5 Site requirements



Refer to the installation manual for complete installation requirements and specifications.

- A power supply circuit installed in accordance with the current edition of NEC (ANSI/NFPA 70) and local codes and ordinances.



- Always consult local and national electrical codes before installing the unit.
- Damage or premature failure of the quoted equipment resulting from improper voltage conditions, inadequate electrical service, or operating the equipment with excessive THD (Total Harmonic Distortion) levels will void the Manufacturer's warranty.

- A power supply with a voltage rating of 60Hz, single phase, in 115V or 208/230V in accordance with the model specified.
- All responsible parties must verify that the electrical supply is properly grounded, free of excessive electrical noise, and within the specified voltage and frequency limits before energizing the unit. Failure to correct power quality issues, including voltage instability or electrical noise, may result in equipment damage and will void the warranty for affected components.
- A properly installed condensate drain line.
- An internal condensate drain line is highly recommended.
- If using an externally run condensate line, note the following:
  - The line must be properly insulated.
  - There needs to be a slope of at least 30%.
  - It is highly recommended that you use a heat trace wire on the condensate line to inhibit freezing. This can be connected to the heat trace power connection on the bottom of the unit.
  - If on a low floor, ensure that the end of the drain is above the maximum height of snow buildup.
- Interior clearances are only required to prevent vibrations. Leave at least 1/8" (8.5 mm) of clearance from any surface. All other clearances are dependent on the ducting.
- Approved louvers must be installed with best practices to ensure that no water enters the wall assembly.
- The unit is intended for ducted installation. Installation without ductwork may result in airflow performance issues.
- The unit must be perfectly level on the horizontal axis and perfectly plumb on the vertical axis.
- The unit must be attached to the ducts tightly, with zero leakage between the external ducts and the unit. If the wall is not plumb, use insulating material.
- The ceiling bracket must be properly affixed to studs or other supporting material.

- Unblocked vents on the exterior, with no obstacles within 36" (914.4 mm) of the air intake and discharge.
- An access panel with adequate clearance to be able to access the entire bottom of the unit for servicing.

## 4.6 Louver specifications

AIO Ceiling Suspended units can be vented using many kinds of custom and creative solutions. The possibilities are endless, from perforated panels to custom louvers. There are two critical factors in selecting and sizing a solution that will work with AIO Ceiling Suspended units.

- **Free area:** The area on a louver/grille that is open for the air to flow through. The louver, perforated panel, or other solution must have at least the amount of free area specified in the specifications below in the plenum from the unit, so that ample air can enter and exit the condenser chamber. A more restrictive solution with a smaller free area can be utilized by enlarging the louver and plenum until the required free area is achieved.



The minimum free area required is 0.34 square feet (0.03 square meters) for the intake vent and 0.34 square feet (0.03 square meters) for the exhaust vent.

- **Pressure drop:** Pressure drop is the resistance the louver/grille creates against the airflow. This resistance can create heat build-up inside the condenser portion, causing the compressor to overheat and shut down. A solution with a higher pressure drop than specified can be utilized by enlarging the louver and plenum until the pressure drop is within specification.



- The maximum total pressure for the intake and exhaust ducting (if any) and intake and exhaust louvers combined must be under 0.45 inWC

(112.1 Pa).

- To be clear, the entire assembly of ductwork, plenums, and louvers for the complete air circuit, in and out of the system, may not exceed 0.45 inWC (112.1 Pa).
- Any louver or louver assembly must meet these requirements, because exceeding these limits can cause the unit to overheat and fail. This will void the warranty.

The following louvers are approved for use with AIO Ceiling Suspended units:

- **Sunvent:** LLA/C, LLA/M, LLA/S - available through your Ephoca distributor.
- **Thermax:** RLA8 - available through your Ephoca distributor.

## 4.7 Minimum installation distances

The clearance zones for the installation and maintenance of the appliance are shown in the figure. Established spaces are necessary to avoid barriers to airflow and allow for normal cleaning and maintenance.



Make sure that there is sufficient space to allow the panels to be removed for routine and supplementary maintenance operations.

Figure 7. Minimum installation distances

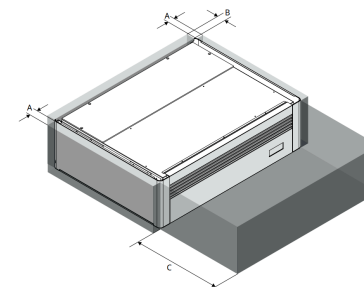
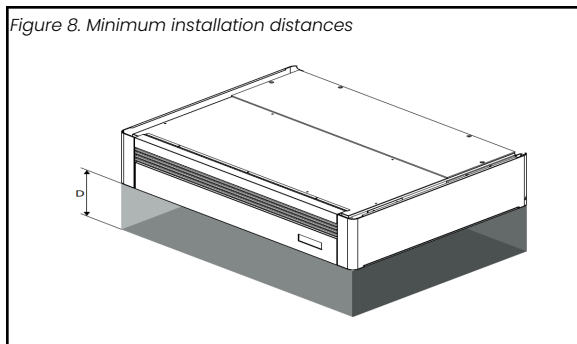

Figure 8. Minimum installation distances



**Minimum distances**

- **A:** 1.2 in (30.5 mm)
- **B:** 1.2 in (30.5 mm)
- **C:** 19.7 in (500.4 mm)
- **D:** 9.8 in (248.9 mm)



If the unit is installed without flanges, place the appliance flush against the wall, disregarding the minimum installation distance 'B' mentioned earlier.

**5. TECHNICAL SPECIFICATIONS**

**5.1 High Performance**

**5.1.1 Cooling**

Table 1. High Performance - Cooling

Heat Pump			95°F (35°C) (1)	105°F (40.6°C) (2)	115°F (46.1°C) (3)
Capacity	Maximum	BTU/hr	15,000	11,400	9,825
	Recommended*		9,400	8,200	7,300
	Rated		7,700	7,345	6,550
	Minimum		3,100	3,100	3,100
Input Power	Maximum	W	1,580	1,640	1,700
	Recommended*		960	950	1,040
	Rated		732	825	904
	Minimum		230	255	285
Efficiency	Maximum	EER	9.49	6.96	5.78
	Recommended*		9.79	8.60	7.0
	Rated		10.55	8.90	7.25
	Seasonal	SEER2	13.85	-	-
Moisture Removal		Pts/h	1.8	2.0	2.2
		L/hr	0.9	0.9	1.0

**Notes**

- (1) ID: 80°F(26.7°C), W.B. 67°F(19.4°C) | OD: 95°F(35°C), W.B. 75°F(23.9°C)
- (2) ID: 80°F(26.7°C), W.B. 67°F(19.4°C) | OD: 105°F(40.6°C), W.B. 75°F(23.9°C)
- (3) ID: 80°F(26.7°C), W.B. 67°F(19.4°C) | OD: 115°F(46.1°C), W.B. 75°F(23.9°C)

\* This is the recommended capacity for sizing the unit to the space

**5.1.2 Heating - Heat pump only**

Table 2. High Performance - Heating

Heat Pump			47°F (8.3°C) (1)	17°F (-8.3°C) (2)	5°F (-15°C) (3)	0°F (-17.8°C) (4)	-5°F (-20.6°C) (5)
Capacity	Maximum	BTU/hr	14,000	10,000	6,600	6,300	5,800
	Recommended*		9,200	9,300	6,200	5,935	5,570
	Rated		8,600	8,300	6,200	5,935	5,570
	Minimum		3,500	3,300	2,800	2,500	2,500
Input Power	Maximum	W	1,420	1,460	1,700	1,600	1,650
	Recommended*		774	990	1,086	1,062	1,013
	Rated		695	860	1,086	1,062	1,013
	Minimum		315	420	440	430	480
Efficiency	Maximum	COP	2.89	2.01	1.13	1.14	1.04
	Recommended*		3.48	2.80	1.68	1.64	1.61
	Rated		3.64	2.83	1.68	1.64	1.61
	Minimum	3.26	2.30	1.87	1.70	1.53	
	Seasonal	HSPF 2	9.15	-	-	-	-

**Notes**

- (1) ID: 70°F(21.1°C), W.B. 60°F(15.6°C) | OD: 47°F(8.3°C), W.B. 43°F(6.1°C)
- (2) ID: 70°F(21.1°C), W.B. 60°F(15.6°C) | OD: 17°F(-8.3°C), W.B. 13°F(-10.6°C)
- (3) ID: 70°F(21.1°C), W.B. 60°F(15.6°C) | OD: 5°F(-15°C), W.B. 3°F(-16.1°C)
- (4) ID: 70°F(21.1°C), W.B. 60°F(15.6°C) | OD: 0°F(-17.8°C)
- (5) ID: 70°F(21.1°C), W.B. 60°F(15.6°C) | OD: -5°F(-20.6°C)

\* This is the recommended capacity for sizing the unit to the space



Optional heat strips are available for an additional 6,100 BTU/hr of heating capacity.

## 5.2 Energy Star Compliant

### 5.2.1 Cooling

Table 3. Energy Star Compliant - Cooling

Heat Pump			95°F (35°C) (1)	105°F (40.6°C) (2)	115°F (46.1°C) (3)
Capacity	Maximum	BTU/hr	15,000	11,400	9,825
	Recommended*		9,400	8,200	7,300
	Rated		6,100	7,345	6,550
	Minimum		3,100	3,100	3,100
Input Power	Maximum	W	1,580	1,640	1,700
	Recommended*		960	950	1,040
	Rated		528	825	904
	Minimum		230	255	285
Efficiency	Maximum	EER	9.49	6.96	5.78
	Recommended*		9.79	8.60	7.00
	Rated		11.56	8.90	7.25
	Seasonal	SEER2	15.3	-	-
Moisture Removal	Pts/h		1.8	2.0	2.2
	l/hr		0.9	0.9	1.0

#### Notes

- (1) ID: 80°F(26.7°C), W.B. 67°F(19.4°C) | OD: 95°F(35°C), W.B. 75°F(23.9°C)  
 (2) ID: 80°F(26.7°C), W.B. 67°F(19.4°C) | OD: 105°F(40.6°C), W.B. 75°F(23.9°C)  
 (3) ID: 80°F(26.7°C), W.B. 67°F(19.4°C) | OD: 115°F(46.1°C), W.B. 75°F(23.9°C)  
 \* This is the recommended capacity for sizing the unit to the space

### 5.2.2 Heating - Heat pump only

Table 4. Energy Star Compliant - Heating

Heat Pump			47°F (8.3°C) (1)	17°F (-8.3°C) (2)	5°F (-15°C) (3)	0°F (-17.8°C) (4)	-5°F (-20.6°C) (5)
Capacity	Maximum	BTU/hr	14,000	10,000	6,600	6,300	5,800
	Recommended*		9,200	8,700	6,200	5,935	5,570
	Rated		8,200	7,800	5,900	5,935	5,570
	Minimum		3,500	3,300	2,800	2,500	2,500
Input Power	Maximum	W	1,420	1,460	1,700	1,600	1,650
	Recommended*		774	920	1,086	1,062	1,013
	Rated		640	804	988	1,062	1,013
	Minimum		315	420	440	430	480
Efficiency	Maximum	COP	2.89	2.01	1.13	1.14	1.04
	Recommended*		3.48	2.8	1.68	1.64	1.61
	Rated		3.76	2.84	1.75	1.64	1.61
	Minimum		3.26	2.30	1.87	1.70	1.53
	Seasonal	HSPF 2	9.2	-	-	-	-

#### Notes

- (6) ID: 70°F(21.1°C), W.B. 60°F(15.6°C) | OD: 47°F(8.3°C), W.B. 43°F(6.1°C)  
 (7) ID: 70°F(21.1°C), W.B. 60°F(15.6°C) | OD: 17°F(-8.3°C), W.B. 13°F(-10.6°C)  
 (8) ID: 70°F(21.1°C), W.B. 60°F(15.6°C) | OD: 5°F(-15°C), W.B. 3°F(-16.1°C)  
 (9) ID: 70°F(21.1°C), W.B. 60°F(15.6°C) | OD: 0°F(-17.8°C)  
 (10) ID: 70°F(21.1°C), W.B. 60°F(15.6°C) | OD: -5°F(-20.6°C)  
 \* This is the recommended capacity for sizing the unit to the space



Optional heat strips are available for an additional 6,100 BTU/hr of heating capacity.

## 5.3 Airflow

### 5.3.1 Indoor

Table 5. Airflow - Indoor

Air volume		
Indoor	Type	ECM centrifugal
	CFM	226 - 350
	m <sup>3</sup> /hr	384 - 595
	Available ESP	-
	Supply connection	Integrated front
	Return connection	Integrated bottom
	Speeds	Low, med, high, boost, auto
	Filter	MERV 3

### 5.3.2 Outdoor

Table 6. Airflow - Outdoor

Air volume		
Outdoor	Type	ECM centrifugal
	CFM	385 - 638
	m <sup>3</sup> /hr	654 - 1084
	Available ESP	No ERV: 0.45" WC (112.1 Pa)
	Intake and Exhaust Connection	6" (15.2 cm) round
	Speeds	Low, med, high, auto

## 5.4 Sound

Table 7. Sound

Sound				
Location	Distance	Fan Speed	Sound Level (dB(A))	
Indoor	-	Range	27 - 43	
		1 m	Level 1 - Low	37
			Level 2 - Medium	47
	Level 3 - High		48	
	3 m	Level 1 - Low	29	
		Level 2 - Medium	39	
Level 3 - High		40		
Outdoor	-	Range	28 - 56	

## 5.5 General

### 5.5.1 Controls

Table 8. Controls

Controls	
Basic functionality	Dependent on the controller
WiFi	Optional module available
Dry contact	Yes
Power outage restart	Auto-on based on the last setting

### 5.5.2 Modes

Table 9. Modes

Modes	
Operation	Cool, heat, dehumidify, auto, fan only
Restricted modes	Heat only, cool only, temperature limiting
Timers	Dependent on the controller

### 5.5.3 Condensate

Table 10. Condensate

Condensate	
Pipe size	3/4" (19 mm) outside diameter
Pipe material	Rubber

### 5.5.4 Compressor

Table 11. Compressor

Compressor		
Type	BLDC twin rotary inverter	
Refrigerant	Type	R32
	Charge	16.93 oz. 0.48 kg
Oil Type	Fv50s (ISO 50) Polyvinylether (PVE)	

### 5.5.5 Physical data

Table 12. Physical data

Physical data			
Dimensions	Net	in	43.0 W x 32.4 D x 12.4 H
		cm	109.2 W x 82.3 H x 31.5 D
Weight	Net		156lb (70.8 kg)
		Gross	165lb (86.1 kg)
Cabinet	Finish		RAL 9003 signal white
		Material	Steel

## 5.6 Electrical

### 5.6.1 General

Table 13. General

General		115V	230V
Volt range		103 - 127	180-253
Hz/phase		60 Hz / single phase	
Power input connection		Hardwire	LDCI power cord or hardwire
Power factor		0.96	
Input power (standby)	W	10.8	
Input power (off mode)		1.5	
Cooling (nominal)	A	8.2	4.1
Cooling (max)		19.1	9.0
Cooling - heat pump + ERV (max)		20.9	9.5
Heat Pump Only			
Heating - heat pump only (nom.)	A	10.0	5.0
Heating-heat pump only (max)		19.8	9.0
Heat Pump + Elec Heat, 900 W for 120V version and 1,800 W for 230V version			
Heating-heat pump+ Elec Heat (nom.)	A	10.0	5.0
Heating-heat pump+ Elec Heat (max)		28.0	16.8

### 5.6.2 Compressor

Table 14. Compressor

Compressor			115V	230V
Compressor	RLA	A	13.0	6.0
	LRA		13.0	6.0
Indoor ECM fan motor	W (max)	A	260	190
	F.L.A.		3.4	1.2
	HP		0.125	0.10
Outdoor ECM fan motor - heat pump only	W (max)	A	220	200
	FLA		2.8	1.4
	HP		0.10	0.10
Outdoor ECM fan motor - heat pump + heater	W (max)	A	220	200
	FLA		2.8	1.4
	HP		0.10	0.10

### 5.6.3 Circuit breakers

Table 15. Circuit breakers

Circuit breakers			115V	230V
Heat Pump Only	MCA	A	24	11
	Recommended breaker size		30	15
	MOCP		35	15
Heat Pump + 900W Elec Heat	MCA	A	31	-
	Recommended breaker size		35	-
	MOCP		40	-
Heat Pump + 1,800W Elec Heat	MCA	A	-	19
	Recommended breaker size		-	20
	MOCP		-	20

### 5.6.4 LCDI power cords

Table 16. LCDI power cords

LCDI Power Cord		115 V	230V
Heat Pump Only	Amps	LCDI cord is not available in 115V above 20 A.	15
	Whip		40" (102cm)
	Plug Type		6-15P
Heat Pump+1800W Elec Heat	Amps	LCDI cord is not available in 115V above 20 A.	20
	Whip		40" (102cm)
	Plug Type		6-20P

## 6. WIRING DIAGRAM

To view the diagram as a high-resolution PNG, click the link below:

[PDF AIO Ceiling Suspended \(without ERV option\) Wirin...](#)

Figure 9. Wiring diagram

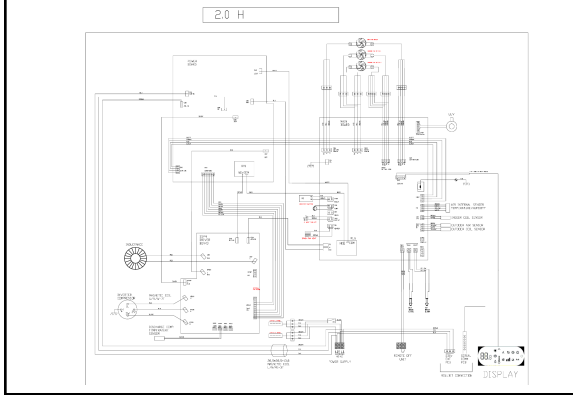

## 6.1 Notes

Table 17. Notes

Description			
Digital Inputs	CN13	Door	Presence contact for CP terminals (presence contact)
	CN14		Drain pump start level
	CN15		Drain alarm
Analog Inputs	ZE		Internal air quality sensor (placed on air inlet)
	HU		Internal air Humidity and temperature Probes (placed on air inlet)
	CN17	OT	External temperature probe (placed on external air inlet) NTC 5.28kΩ at 77°F (25°C)
	CN17	OPT	Condenser probe (placed on pipe of external coil) NTC 5.28kΩ at 77°F (25°C)
	CN7	IPT	Evaporator probe (placed on pipe internal coils) NTC 5.28kΩ at 77°F (25°C)
	CN16	GT	Exhaust air probe (placed on air exhaust) NTC 5.28kΩ at 77°F (25°C)
Digital outputs	XP209		Compressor discharge temperature probe NTC 58kΩ at 77°F (25°C)
	CN2	Valve	Summer/winter reversing valve
	CN1	Heater	External heater (230VAC/5A)
Analog outputs	CN4	Pump	Drain pump
	CN23	In fan	Driving signal 0-10V external fan
	CN9	Out fan con	Driving signal 0-10V external fan
	CN19	Step Motor	Driving a step motor for the damper
	CN10	Step Motor	Driving a step motor for the damper
	CN11	Display	Display touch connection

## 7. DIMENSIONS

To view the dimensions as a high-resolution PDF, click the link below:

[PDF AIO Ceiling Suspended \(Without ERV option\) Dim...](#)

Figure 10. Dimensions

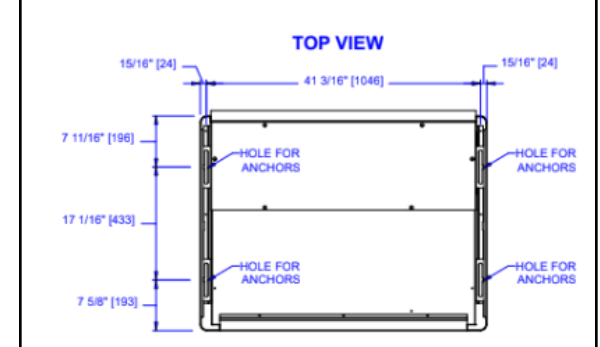

Figure 11. Dimensions

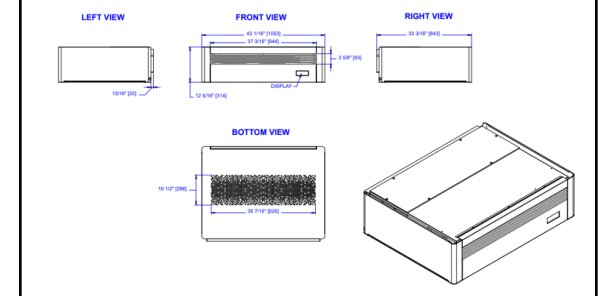
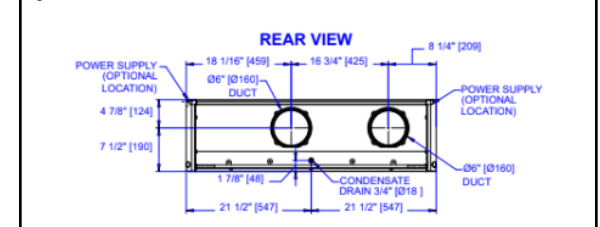

Figure 12. Dimensions





## 10. SUBMITTALS

### 10.1 115V Heat pump only - High Performance

AIO CEILING SUSPENDED - 115V - NO ELECTRIC HEAT STRIP - R32 - SUBMITTAL (ASPI0N3HI)

Job	Reference	Construction
Location	Approval	Quote Number
Engineer	Date	Drawing Number
Submitted To	Submitted By:	P.O. Number:

#### General Features

- BLDC inverter compressor
- ECM fans
- R32 Refrigerant
- Auto restart
- Intelligent defrost
- No outdoor unit
- Onboard touch controller
- Washable filters
- Compact slim design
- 3 selectable fan speeds + Auto
- 10-Year limited warranty (after certification)
- Made in Italy

The installing contractor must contact Ephoca Customer Technical Support prior to installation to schedule an installation training overview.

This may be conducted in person or remotely (online). It is the official installation training and may include videos, best practices, and system requirements.

Performing installations without training may result in installation errors, performance issues, and possible warranty limitations.

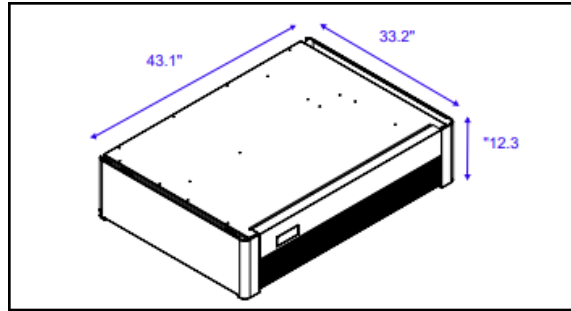

Performance Specifications			
Cooling	Min-Max	BTU/H	15,000 - 3,100
	Rated capacity (95°F)		7,700
	Efficiency		EER2 10.55
Heating	Min-Max	BTU/H	14,000 - 3,500
	Rated capacity (47°F)		8,600
	Rated capacity (5°F)		6,200
	Efficiency		COP2 3.64
Sound	Indoor sound	db(A)	27 - 43
	Outdoor sound		28 - 56
Moisture removal	Moisture removal	Pts/h	1.8
		L/hr	0.9
Airflow	Indoor	CFM	226 - 350
		m <sup>3</sup> /hr	384 - 595
	Outdoor	CFM	385 - 638
		m <sup>3</sup> /hr	654 - 1084

Electric Specifications	
Power Supply (V/Ph/Hz)	115V/1Ph/60Hz
Voltage Range	103-127
Running Amps Cooling	8.2
Running Amps Heating	10.0
MCA	24
Maximum Overcurrent Protection (A)	35
Recommend breaker size	30
Max Power Input (amps) Cooling	19.1
Max Power Input (amps) Heating	19.8

Included	Wall Controllers + Gateways	
<input type="checkbox"/>	Wireless Remote	WRCH20
<input type="checkbox"/>	Basic Touch Controller	LTCH20
<input type="checkbox"/>	Recessed Touch Controller	RTCH20
<input type="checkbox"/>	Advanced TFT Controller with 7-Day program	TFTH20
<input type="checkbox"/>	Wireless (AA Battery) Infrared Controller with 7-Day program	WIPT20
<input type="checkbox"/>	Third Party Gateway	TPG015
<input type="checkbox"/>	WiFi App	WIFI30
<input type="checkbox"/>	E-Paper EOS Controller	EEOS12
<input type="checkbox"/>	Simple EOS Controller	SEOS12
<input type="checkbox"/>	BACnet and Modbus	BACH20
<input type="checkbox"/>	Integration gateway for LTCH20, TFTH20 and MODBUS	GWN
<input type="checkbox"/>	Integration gateway for LTCH20, TFTH20, MODBUS, BACnet, and third-party thermostats	GWX

Included	LCDI Power Cords	Amps	NEMA	SKU
<input type="checkbox"/>	LCDI is not available over 20A for 115V units			

## 10.2 115V Heat pump + elec heat - High Performance

AIO CEILING SUSPENDED - 115V - 900W ELECTRIC HEAT - R32 - SUBMITTAL (ASE10N3HI)

Job	Reference	Construction
Location	Approval	Quote Number
Engineer	Date	Drawing Number
Submitted To	Submitted By:	P.O. Number:

### General Features

- BLDC inverter compressor
- ECM fans
- R32 Refrigerant
- 900W Electric heat supplement
- Auto restart
- Intelligent defrost
- No outdoor unit
- Onboard touch controller
- Washable filters
- Electronically controlled air louver
- Compact slim design
- 3 selectable fan speeds + Auto
- 10-Year limited warranty (after certification)
- Made in Italy

The installing contractor must contact Ephoca Customer Technical Support prior to installation to schedule an installation training overview.

This may be conducted in person or remotely (online). It is the official installation training and may include videos, best practices, and system requirements.

Performing installations without training may result in installation errors, performance issues, and possible warranty limitations.

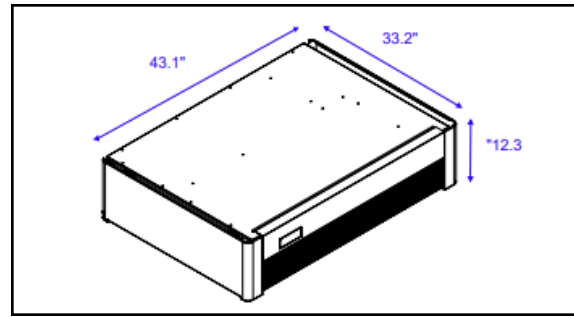

Performance Specifications			
Cooling	Min-Max	BTU/H	15,000 - 3,100
	Rated capacity (95°F)		7,700
	Efficiency		EER2 10.55
Heating	Min-Max	BTU/H	14,000 - 3,500
	Rated capacity (47°F)		8,600
	Rated capacity (5°F)		6,200
	Efficiency		COP2 3.64
Sound	Indoor sound	db(A)	27 - 43
	Outdoor sound		28 - 56
Moisture removal	Moisture removal	Pts/h	1.8
		L/hr	0.9
Airflow	Indoor	CFM	226 - 350
		m <sup>3</sup> /hr	384 - 595
	Outdoor	CFM	385 - 638
		m <sup>3</sup> /hr	654 - 1084

Electric Specifications	
Power Supply (V/Ph/Hz)	115V/1Ph/60Hz
Voltage Range	103-127
Running Amps Cooling	8.2
Running Amps Heating	10.0
MCA	31
Maximum Overcurrent Protection (A)	40
Recommend breaker size	35
Max Power Input (amps) Cooling	19.1
Max Power Input (amps) Heating	28.0

Included	Wall Controllers + Gateways	
<input type="checkbox"/>	Wireless Remote	WRCH20
<input type="checkbox"/>	Basic Touch Controller	LTCH20
<input type="checkbox"/>	Recessed Touch Controller	RTCH20
<input type="checkbox"/>	Advanced TFT Controller with 7-Day program	TFTH20
<input type="checkbox"/>	Wireless (AA Battery) Infrared Controller with 7-Day program	WIPT20
<input type="checkbox"/>	Third Party Gateway	TPG015
<input type="checkbox"/>	WiFi App	WIFI30
<input type="checkbox"/>	E-Paper EOS Controller	EEOS12
<input type="checkbox"/>	Simple EOS Controller	SEOS12
<input type="checkbox"/>	BACnet and Modbus	BACH20
<input type="checkbox"/>	Integration gateway for LTCH20, TFTH20 and MODBUS	GWN
<input type="checkbox"/>	Integration gateway for LTCH20, TFTH20, MODBUS, BACnet, and third-party thermostats	GWX

Included	General Accessories	
<input type="checkbox"/>	Underbody Cover Plate	GB0737II
<input type="checkbox"/>	Reducer Plate from 8" (203.2 mm) to 6" (152.4 mm)	RED2016

Included	LCDI Power Cords	Amps	NEMA	SKU
<input type="checkbox"/>	LCDI is not available over 20A for 115V units			

## 10.3 230V Heat pump only - High Performance

AIO CEILING SUSPENDED - 230V - NO ELECTRIC HEAT STRIP - R32 - SUBMITTAL (ASPION3H2)

Job	Reference	Construction
Location	Approval	Quote Number
Engineer	Date	Drawing Number
Submitted To	Submitted By:	P.O. Number:

### General Features

- BLDC inverter compressor
- ECM fans
- MERV 13 filters on fresh air
- R32 Refrigerant
- Auto restart
- Intelligent defrost
- No outdoor unit
- Onboard touch controller
- Washable filters
- Compact slim design
- 3 selectable fan speeds + Auto
- 10-Year limited warranty (after certification)
- Made in Italy

The installing contractor must contact Ephoca Customer Technical Support prior to installation to schedule an installation training overview.

This may be conducted in person or remotely (online). It is the official installation training and may include videos, best practices, and system requirements.

Performing installations without training may result in installation errors, performance issues, and possible warranty limitations.

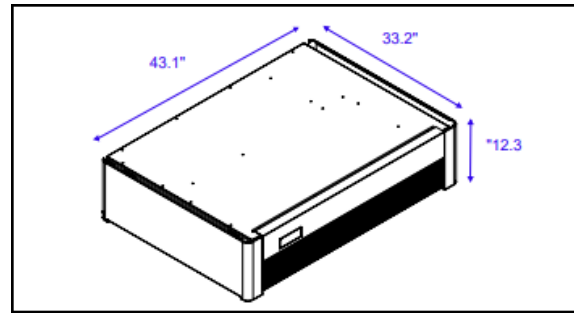

Performance Specifications			
Cooling	Min-Max	BTU/H	15,000 - 3,100
	Rated capacity (95°F)		7,700
	Efficiency		EER2 10.55
Heating	Min-Max	BTU/H	14,000 - 3,500
	Rated capacity (47°F)		8,600
	Rated capacity (5°F)		6,200
	Efficiency		COP2 3.64
Sound	Indoor sound	db(A)	27 - 43
	Outdoor sound		28 - 56
Moisture removal	Moisture removal	Pts/h	1.8
		L/hr	0.9
Airflow	Indoor	CFM	226 - 350
		m <sup>3</sup> /hr	384 - 595
	Outdoor	CFM	385 - 638
		m <sup>3</sup> /hr	654 - 1084

Electric Specifications	
Power Supply (V/Ph/Hz)	230V/1Ph/60Hz
Voltage Range	180-253
Running Amps Cooling	4.1
Running Amps Heating	5.0
MCA	11
Maximum Overcurrent Protection (A)	15
Recommend breaker size	15
Max Power Input (amps) Cooling	9.0
Max Power Input (amps) Heating	9.0

Included	Wall Controllers + Gateways	
<input type="checkbox"/>	Wireless Remote	WRCH20
<input type="checkbox"/>	Basic Touch Controller	LTCH20
<input type="checkbox"/>	Recessed Touch Controller	RTCH20
<input type="checkbox"/>	Advanced TFT Controller with 7-Day program	TFTH20
<input type="checkbox"/>	Wireless (AA Battery) Infrared Controller with 7-Day program	WIPT20
<input type="checkbox"/>	Third Party Gateway	TPG015
<input type="checkbox"/>	WiFi App	WIFI30
<input type="checkbox"/>	E-Paper EOS Controller	EEOS12
<input type="checkbox"/>	Simple EOS Controller	SEOS12
<input type="checkbox"/>	BACnet and Modbus	BACH20
<input type="checkbox"/>	Integration gateway for LTCH20, TFTH20 and MODBUS	GWN
<input type="checkbox"/>	Integration gateway for LTCH20, TFTH20, MODBUS, BACnet, and third-party thermostats	GWX

Included	LCDI Power Cords	Amps	NEMA	SKU
<input type="checkbox"/>	89 in. (2260.6 mm)	15	6-15P	L259A

## 10.4 230V Heat pump + elec heat - High Performance

AIO CEILING SUSPENDED - 230V - 1800W ELECTRIC HEAT - R32 - SUBMITTAL (ASK10N3H2)

Job	Reference	Construction
Location	Approval	Quote Number
Engineer	Date	Drawing Number
Submitted To	Submitted By:	P.O. Number:

### General Features

- BLDC inverter compressor
- ECM fans
- R32 Refrigerant
- Field configured 900W or 1,800W Electric heat supplement
- Auto restart
- Intelligent defrost
- No outdoor unit
- Onboard touch controller
- Washable filters
- Compact slim design
- 3 selectable fan speeds + Auto
- 10-Year limited warranty (after certification)
- Made in Italy

The installing contractor must contact Ephoca Customer Technical Support prior to installation to schedule an installation training overview.

This may be conducted in person or remotely (online). It is the official installation training and may include videos, best practices, and system requirements.

Performing installations without training may result in installation errors, performance issues, and possible warranty limitations.

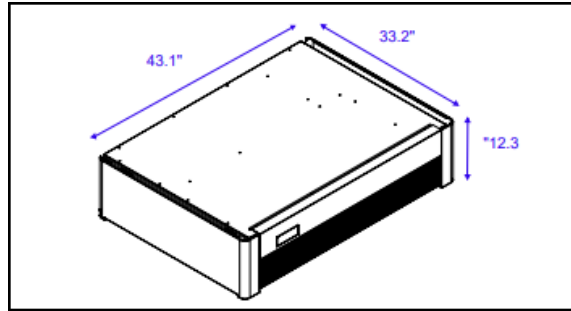

Performance Specifications			
Cooling	Min-Max	BTU/H	15,000 - 3,100
	Rated capacity (95°F)		7,700
	Efficiency		EER2 10.55
Heating	Min-Max	BTU/H	14,000 - 3,500
	Rated capacity (47°F)		8,600
	Rated capacity (5°F)		6,200
	Efficiency		COP2 3.64
Sound	Indoor sound	db(A)	27 - 43
	Outdoor sound		28 - 56
Moisture removal	Moisture removal	Pts/h	1.8
		L/hr	0.9
Airflow	Indoor	CFM	226 - 350
		m <sup>3</sup> /hr	384 - 595
	Outdoor	CFM	385 - 638
		m <sup>3</sup> /hr	654 - 1084

Electric Specifications	
Power Supply (V/Ph/Hz)	230V/1Ph/60Hz
Voltage Range	180-253
Running Amps Cooling	4.1
Running Amps Heating	5.0
MCA	19
Maximum Overcurrent Protection (A)	20
Recommend breaker size	20
Max Power Input (amps) Cooling	9.0
Max Power Input (amps) Heating	16.8

Included	Wall Controllers + Gateways	
<input type="checkbox"/>	Wireless Remote	WRCH20
<input type="checkbox"/>	Basic Touch Controller	LTCH20
<input type="checkbox"/>	Recessed Touch Controller	RTCH20
<input type="checkbox"/>	Advanced TFT Controller with 7-Day program	TFTH20
<input type="checkbox"/>	Wireless (AA Battery) Infrared Controller with 7-Day program	WIPT20
<input type="checkbox"/>	Third Party Gateway	TPG015
<input type="checkbox"/>	WiFi App	WIFI30
<input type="checkbox"/>	E-Paper EOS Controller	EEOS12
<input type="checkbox"/>	Simple EOS Controller	SEOS12
<input type="checkbox"/>	BACnet and Modbus	BACH20
<input type="checkbox"/>	Integration gateway for LTCH20, TFTH20 and MODBUS	GWN
<input type="checkbox"/>	Integration gateway for LTCH20, TFTH20, MODBUS, BACnet, and third-party thermostats	GWX

Included	LCDI Power Cords	Amps	NEMA	SKU
<input type="checkbox"/>	89 in. (2260.6 mm)	20	6-20P	L229A

## 10.5 115V Heat pump only – Energy Star Compliant

AIO CEILING SUSPENDED – 115V – NO ELECTRIC HEAT STRIP – R32 – SUBMITTAL (ASP09N3H1)

Job	Reference	Construction
Location	Approval	Quote Number
Engineer	Date	Drawing Number
Submitted To	Submitted By:	P.O. Number:

### General Features

- BLDC inverter compressor
- ECM fans
- R32 Refrigerant
- Auto restart
- Intelligent defrost
- No outdoor unit
- Onboard touch controller
- Washable filters
- Compact slim design
- 3 selectable fan speeds + Auto
- 10-Year limited warranty (after certification)
- Made in Italy

The installing contractor must contact Ephoca Customer Technical Support prior to installation to schedule an installation training overview.

This may be conducted in person or remotely (online). It is the official installation training and may include videos, best practices, and system requirements.

Performing installations without training may result in installation errors, performance issues, and possible warranty limitations.

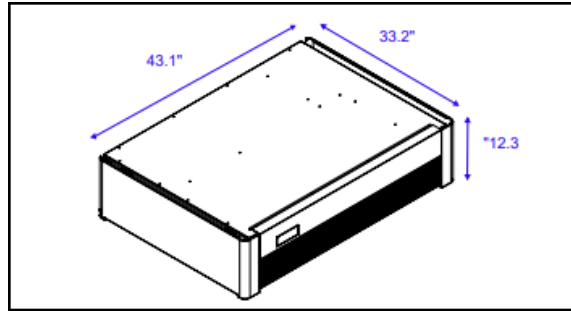

Performance Specifications			
Cooling	Min-Max	BTU/H	15,000 - 3,100
	Rated capacity (95°F)		6,100
	Efficiency	EER2	11.56
Heating	Min-Max	BTU/H	14,000 - 3,500
	Rated capacity (47°F)		8,200
	Rated capacity (5°F)	5,900	
	Efficiency	COP2	3.76
Sound	Indoor sound	db(A)	27 - 43
	Outdoor sound		28 - 56
Moisture removal	Moisture removal	Pts/h	1.8
		L/hr	0.9
Airflow	Indoor	CFM	226 - 350
		m <sup>3</sup> /hr	384 - 595
	Outdoor	CFM	385 - 638
		m <sup>3</sup> /hr	654 - 1084

Electric Specifications	
Power Supply (V/Ph/Hz)	115V/1Ph/60Hz
Voltage Range	103-127
Running Amps Cooling	8.2
Running Amps Heating	10.0
MCA	24
Maximum Overcurrent Protection (A)	35
Recommend breaker size	30
Max Power Input (amps) Cooling	19.1
Max Power Input (amps) Heating	19.8

Included	Wall Controllers + Gateways	
<input type="checkbox"/>	Wireless Remote	WRCH20
<input type="checkbox"/>	Basic Touch Controller	LTCH20
<input type="checkbox"/>	Recessed Touch Controller	RTCH20
<input type="checkbox"/>	Advanced TFT Controller with 7-Day program	TFTH20
<input type="checkbox"/>	Wireless (AA Battery) Infrared Controller with 7-Day program	WIPT20
<input type="checkbox"/>	Third Party Gateway	TPG015
<input type="checkbox"/>	WiFi App	WIFI30
<input type="checkbox"/>	E-Paper EOS Controller	EEOS12
<input type="checkbox"/>	Simple EOS Controller	SEOS12
<input type="checkbox"/>	BACnet and Modbus	BACH20
<input type="checkbox"/>	Integration gateway for LTCH20, TFTH20 and MODBUS	GWN
<input type="checkbox"/>	Integration gateway for LTCH20, TFTH20, MODBUS, BACnet, and third-party thermostats	GWX

Included	LCDI Power Cords	NEMA	SKU
<input type="checkbox"/>	72 in. (1828.8 mm)	6-15P	L115v15a

## 10.6 115V Heat pump + elec heat - Energy Star Compliant

AIO CEILING SUSPENDED - 115V - 900W ELECTRIC HEAT - R32 - SUBMITTAL (ASE09N3H1)

Job	Reference	Construction
Location	Approval	Quote Number
Engineer	Date	Drawing Number
Submitted To	Submitted By:	P.O. Number:

### General Features

- BLDC inverter compressor
- ECM fans
- R32 Refrigerant
- 900W Electric heat supplement
- Auto restart
- Intelligent defrost
- No outdoor unit
- Onboard touch controller
- Washable filters
- Electronically controlled air louver
- Compact slim design
- 3 selectable fan speeds + Auto
- 10-Year limited warranty (after certification)
- Made in Italy

The installing contractor must contact Ephoca Customer Technical Support prior to installation to schedule an installation training overview.

This may be conducted in person or remotely (online). It is the official installation training and may include videos, best practices, and system requirements.

Performing installations without training may result in installation errors, performance issues, and possible warranty limitations.

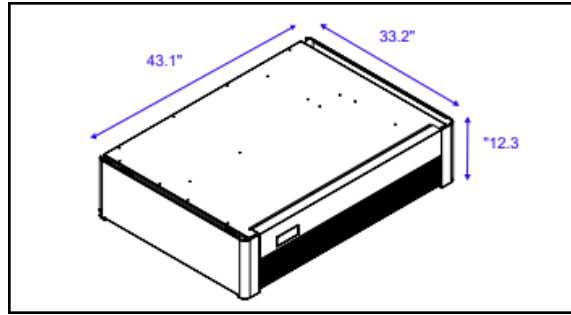

Performance Specifications			
Cooling	Min-Max	BTU/H	15,000 - 3,100
	Rated capacity (95°F)		6,100
	Efficiency	EER2	11.56
Heating	Min-Max	BTU/H	14,000 - 3,500
	Rated capacity (47°F)		8,200
	Rated capacity (5°F)	5,900	
	Efficiency	COP2	3.76
Sound	Indoor sound	db(A)	27 - 43
	Outdoor sound		28 - 56
Moisture removal	Moisture removal	Pts/h	1.8
		L/hr	0.9
Airflow	Indoor	CFM	226 - 350
		m <sup>3</sup> /hr	384 - 595
	Outdoor	CFM	385 - 638
		m <sup>3</sup> /hr	654 - 1084

Electric Specifications	
Power Supply (V/Ph/Hz)	115V/1Ph/60Hz
Voltage Range	103-127
Running Amps Cooling	8.2
Running Amps Heating	10.0
MCA	31
Maximum Overcurrent Protection (A)	40
Recommend breaker size	35
Max Power Input (amps) Cooling	19.1
Max Power Input (amps) Heating	28.0

Included	Wall Controllers + Gateways	
<input type="checkbox"/>	Wireless Remote	WRCH20
<input type="checkbox"/>	Basic Touch Controller	LTCH20
<input type="checkbox"/>	Recessed Touch Controller	RTCH20
<input type="checkbox"/>	Advanced TFT Controller with 7-Day program	TFTH20
<input type="checkbox"/>	Wireless (AA Battery) Infrared Controller with 7-Day program	WIPT20
<input type="checkbox"/>	Third Party Gateway	TPG015
<input type="checkbox"/>	WiFi App	WIFI30
<input type="checkbox"/>	E-Paper EOS Controller	EEOS12
<input type="checkbox"/>	Simple EOS Controller	SEOS12
<input type="checkbox"/>	BACnet and Modbus	BACH20
<input type="checkbox"/>	Integration gateway for LTCH20, TFTH20 and MODBUS	GWN
<input type="checkbox"/>	Integration gateway for LTCH20, TFTH20, MODBUS, BACnet, and third-party thermostats	GWX

## 10.7 230V Heat pump only – Energy Star Compliant

AIO CEILING SUSPENDED – 230V – NO ELECTRIC HEAT STRIP – R32 – SUBMITTAL (ASP09N3H2)

Job	Reference	Construction
Location	Approval	Quote Number
Engineer	Date	Drawing Number
Submitted To	Submitted By:	P.O. Number:

### General Features

- BLDC inverter compressor
- ECM fans
- MERV 13 filters on fresh air
- R32 Refrigerant
- Auto restart
- Intelligent defrost
- No outdoor unit
- Onboard touch controller
- Washable filters
- Compact slim design
- 3 selectable fan speeds + Auto
- 10-Year limited warranty (after certification)
- Made in Italy

The installing contractor must contact Ephoca Customer Technical Support prior to installation to schedule an installation training overview.

This may be conducted in person or remotely (online). It is the official installation training and may include videos, best practices, and system requirements.

Performing installations without training may result in installation errors, performance issues, and possible warranty limitations.

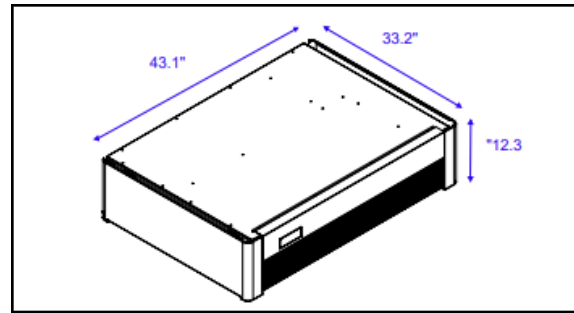

Performance Specifications			
Cooling	Min-Max	BTU/H	15,000 - 3,100
	Rated capacity (95°F)		6,100
	Efficiency		EER2 11.56
Heating	Min-Max	BTU/H	14,000 - 3,500
	Rated capacity (47°F)		8,200
	Rated capacity (5°F)		5,900
	Efficiency		COP2 3.76
Sound	Indoor sound	db(A)	27 - 43
	Outdoor sound		28 - 56
Moisture removal	Moisture removal	Pts/h	1.8
		L/hr	0.9
Airflow	Indoor	CFM	226 - 350
		m <sup>3</sup> /hr	384 - 595
	Outdoor	CFM	385 - 638
		m <sup>3</sup> /hr	654 - 1084

Electric Specifications	
Power Supply (V/Ph/Hz)	230V/1Ph/60Hz
Voltage Range	180-253
Running Amps Cooling	4.1
Running Amps Heating	5.0
MCA	11
Maximum Overcurrent Protection (A)	15
Recommend breaker size	15
Max Power Input (amps) Cooling	9.0
Max Power Input (amps) Heating	9.0

Included	Wall Controllers + Gateways	
<input type="checkbox"/>	Wireless Remote	WRCH20
<input type="checkbox"/>	Basic Touch Controller	LTCH20
<input type="checkbox"/>	Recessed Touch Controller	RTCH20
<input type="checkbox"/>	Advanced TFT Controller with 7-Day program	TFTH20
<input type="checkbox"/>	Wireless (AA Battery) Infrared Controller with 7-Day program	WIPT20
<input type="checkbox"/>	Third Party Gateway	TPG015
<input type="checkbox"/>	WiFi App	WIFI30
<input type="checkbox"/>	E-Paper EOS Controller	EEOS12
<input type="checkbox"/>	Simple EOS Controller	SEOS12
<input type="checkbox"/>	BACnet and Modbus	BACH20
<input type="checkbox"/>	Integration gateway for LTCH20, TFTH20 and MODBUS	GWN
<input type="checkbox"/>	Integration gateway for LTCH20, TFTH20, MODBUS, BACnet, and third-party thermostats	GWX

Included	LCDI Power Cords	Amps	NEMA	SKU
<input type="checkbox"/>	89 in. (2260.6 mm)	15	6-15P	L259A

## 10.8 230V Heat pump + elec heat - Energy Star Compliant

AIO CEILING SUSPENDED - 230V - 1800W ELECTRIC HEAT - R32 - SUBMITTAL (ASK09N3H2)

Job	Reference	Construction
Location	Approval	Quote Number
Engineer	Date	Drawing Number
Submitted To	Submitted By:	P.O. Number:

### General Features

- BLDC inverter compressor
- ECM fans
- R32 Refrigerant
- Field configured 900W or 1,800W Electric heat supplement
- Auto restart
- Intelligent defrost
- No outdoor unit
- Onboard touch controller
- Washable filters
- Compact slim design
- 3 selectable fan speeds + Auto
- 10-Year limited warranty (after certification)
- Made in Italy

The installing contractor must contact Ephoca Customer Technical Support prior to installation to schedule an installation training overview.

This may be conducted in person or remotely (online). It is the official installation training and may include videos, best practices, and system requirements.

Performing installations without training may result in installation errors, performance issues, and possible warranty limitations.

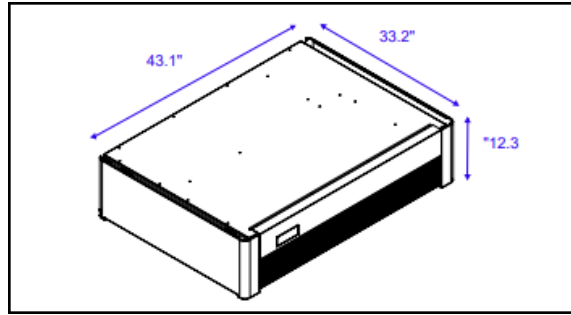

Performance Specifications			
Cooling	Min-Max	BTU/H	15,000 - 3,100
	Rated capacity (95°F)		6,100
	Efficiency		EER2 11.56
Heating	Min-Max	BTU/H	14,000 - 3,500
	Rated capacity (47°F)		8,200
	Rated capacity (5°F)		5,900
	Efficiency		COP2 3.76
Sound	Indoor sound	db(A)	27 - 43
	Outdoor sound		28 - 56
Moisture removal	Moisture removal	Pts/h	1.8
		L/hr	0.9
Airflow	Indoor	CFM	226 - 350
		m <sup>3</sup> /hr	384 - 595
	Outdoor	CFM	385 - 638
		m <sup>3</sup> /hr	654 - 1084

Electric Specifications	
Power Supply (V/Ph/Hz)	230V/1Ph/60Hz
Voltage Range	180-253
Running Amps Cooling	4.1
Running Amps Heating	5.0
MCA	19
Maximum Overcurrent Protection (A)	20
Recommend breaker size	20
Max Power Input (amps) Cooling	9.0
Max Power Input (amps) Heating	16.8

Included	Wall Controllers + Gateways	
<input type="checkbox"/>	Wireless Remote	WRCH20
<input type="checkbox"/>	Basic Touch Controller	LTCH20
<input type="checkbox"/>	Recessed Touch Controller	RTCH20
<input type="checkbox"/>	Advanced TFT Controller with 7-Day program	TFTH20
<input type="checkbox"/>	Wireless (AA Battery) Infrared Controller with 7-Day program	WIPT20
<input type="checkbox"/>	Third Party Gateway	TPG015
<input type="checkbox"/>	WiFi App	WIFI30
<input type="checkbox"/>	E-Paper EOS Controller	EEOS12
<input type="checkbox"/>	Simple EOS Controller	SEOS12
<input type="checkbox"/>	BACnet and Modbus	BACH20
<input type="checkbox"/>	Integration gateway for LTCH20, TFTH20 and MODBUS	GWN
<input type="checkbox"/>	Integration gateway for LTCH20, TFTH20, MODBUS, BACnet, and third-party thermostats	GWX

Included	LCDI Power Cords	Amps	NEMA	SKU
<input type="checkbox"/>	89 in. (2260.6 mm)	20	6-20P	L229A



With over 20 years of experience in the climate comfort sector, we have a clear goal: growth through innovation. Our team is laser-focused on the conception, development, and production of innovative heating, ventilation, and air conditioning solutions. This mission has developed through bringing together technical skills, creativity, technology, design, Italian passion, and a global vision to achieve the best energy efficiency and performance.

Ephoca is the US subsidiary of Innova SRL -  
Via 1° Maggio, 8 - 38089 Storo (TN), Italy.

[ephoca.com](http://ephoca.com) | 216-710-1000

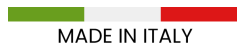

© 2026 Ephoca. All rights reserved.

AIO Ceiling Suspended (without ERV option)  
Product Data Sheet  
Updated Apr 5, 2026